

Table of contents

Category	Index	Page
Business Company	Chronology / Array of products	2-3
UPS classification	UPS classification / Technology	4-5
AC line-interactive UPS 400-3200VA	ME series	6-7
	MI-RM series	8-9
	MTD series	NEU / NEW 10-11
	MTD-RM series	NEU / NEW 12-13
	MT series	14-15
	MT-RM series	16-17
AC online double-conversion UPS 700-3000VA	MKD series	18-19
	MKD-RM series	20-21
	MH/MHD series	22-23
	MH-RM/MHD-RM series	24-25
AC large UPS 6-300kVA	MH 6000	26-27
	MH 6000 RM	28-29
	MHD 10-20kVA	30-31
	MHD RM 10kVA	NEU / NEW 32-33
	Quasar II	NEU / NEW 34-35
	Quasar 60-120kVA	36-37
	Pegasus 10-40kVA	38-39
	Pegasus 60-160kVA	40-41
AC large modular UPS 4-120kVA	Pegasus 200-300kVA	42-43
	MHD Modular	44-47
UPS-Management	MHD Modular P3	NEU / NEW 48-49
	Software	50-51
Accessories	SNMP / web adapters	52-53
	External bypass	54
Batteries	Battery-cabinet	55
	BT series batteries	56-57
	BTL series batteries	58-59
	Front terminal batteries	60
	Terminal types	61
	BACS battery management	62-69
AC/DC power supplies, chargers, inverters / rectifiers	DC UPS, DIN-rail	70-71
	Modular DC power supply systems 48-60V	72-87
	Modular DC power supply systems 108-220V	88-91
	EFFEKTA Charger	NEU / NEW 92-93
	Mascot power supplies, chargers, converters	94-95
	Solar inverter	NEU / NEW 96-97
	Solar-Log™	NEU / NEW 98-99
	Mobile inverters WRI	NEU / NEW 100-101
	Mobile inverters WRS	102-103
Special appliances AC	Special appliances	104-105
Service	Service	106-107
References	References	108-109
AGBs	Terms & Conditions	110

Business Company



Chronology & development:

- Foundations:

- HJ Elektronik in 1984
- EFFEKTA® Regeltechnik GmbH in 1990
- EFFEKTA® (Taiwan) in 1991
- EFFEKTA® (Hungary) in 1998
- Rottweil sales department in 1999
- Amalgamation of business of Tettnang and Rottweil in Rheinwaldstraße 34, Rottweil in 2007

- Management-buy-out in 2000 with new directors:

P. Androt, G. Kremer and R. Schmeh

- Today:

the company employs 62 staff.

EFFEKTA® has been successfully operating on the UPS market for over 18 years. Over the years, our company has come to epitomise reliability and quality and we are now one of the leading UPS manufacturers in Germany. This success has been made possible by consistent ongoing, development and the use of innovative technology.

The fact that EFFEKTA® UPSs are used every day in renowned companies such as Berliner Verkehrsbetriebe (Berlin Municipal Transport Company), Daimler Chrysler, SIEMENS, Deutsche Telekom, BASF, Bayer-Leverkusen, Deutsches Institut für Luft- und Raumfahrt (German Aerospace Centre) and many more is testament to their high quality (s. p. 110/111).



UPS-Systems
 Pegasus 10-40 kVA
 Pegasus 60-160 kVA
 Pegasus 200-300 kVA
 (from left to right)

Most UPSs are employed to safeguard data processing functions in case of power disturbances. EFFEKTA® UPSs are not only suited to use with computers, but also with all sensitive, power-dependent units.

The EFFEKTA® range provides a solution for every kind of application we have got a solution. We are also experienced in custom designs and small production runs.

We now have expanded our array of products to include rectifiers, inverters and power supplies for every requirement and also DC UPSs for telecommunications or wireless network operators.

All models come in standard enclosures or can be supplied for switchboards or DIN-rails.

Leasing with our partner VR LEASING is available hence.



Our array of products:

- Line-interactive UPSs up to 3.2kVA
- Online double-conversion UPSs up to 800kVA
- Single- and three-phase standalone units
- 19" versions and more special enclosures
- Redundant systems, AC and DC up to 800kVA (KW)
- UPS management solutions
- Inverters / rectifiers
- DC UPS systems
- Power supplies
- Batteries 2/6/12V, 0.8 ... 2000Ah
- "BACS" battery control/-management
- **Custom solutions**



EFFEKTA® family of batteries

UPS classification

Usable UPS class	Power disturbance						
	Power failure >10ms	Voltage fluctuations <16 ms	Peaks 4-16ms	Under-voltage	Over-voltage	Lightning effects	Surge <4ms
VFI	✓	✓	✓	✓	✓	✓	✓
VI	✓	✓	✓	✓	✓	✗	✗
VFD	✓	✓	✓	✗	✗	✗	✗

Two different technologies are used to provide a consumer with uninterrupted power. The norms EN 50091-3 and IEC 62040-3 serve to differentiate the two technologies and assess their protection.

VFI: UPS output voltage **and** frequency are **independent** of line voltage **and** frequency or comparable modifications.

Previously used definitions: online double-conversion, continuous operation

Units: MH, MH-RM, MHD, MHD-RM, MKD, MKD-RM, Pegasus, Quasar, Quasar II

VI: UPS output voltage is **independent** of line voltage or comparable modifications (voltage-stabilized)

Previously used definitions: line-interactive, single-conversion, delta conversion

Units: MT, MT-RM, ME, MI-RM, MTD, MTD-RM

VFD: UPS output frequency **and** output voltage is **dependent** on line frequency **and** line voltage or comparable modifications

Previous used definition: off-line, stand-by

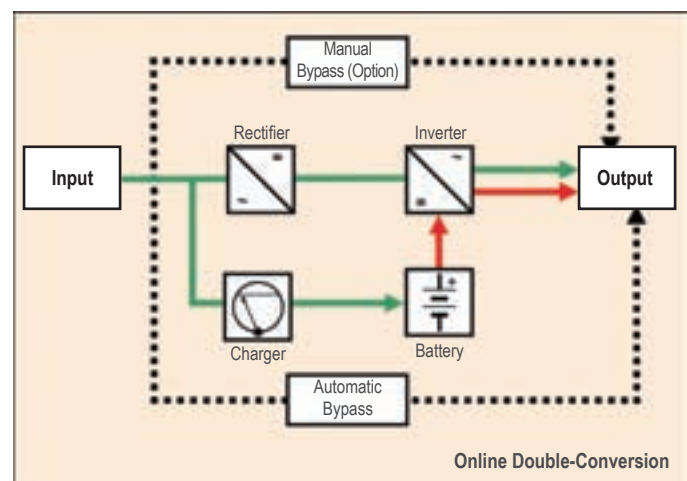
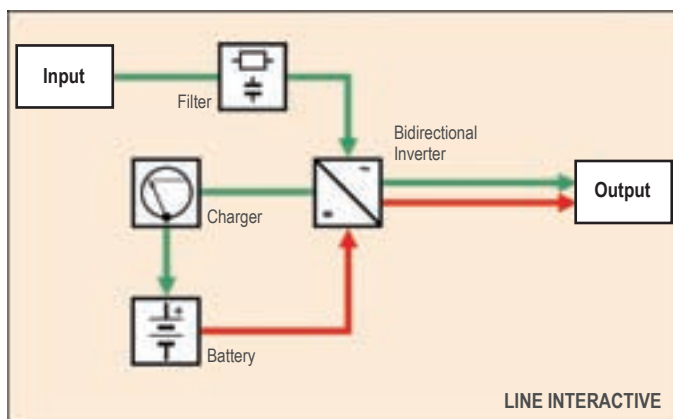

Line-interactive systems (VI)

- Short transfer time
- Bi-directional inverter
- Output voltage mostly pure sine wave / in some cases modified sine wave
- Attractive price
- Booster-function

Areas of application:

- Telecommunications
- CAD appliances
- SPS systems
- Small servers

Models:

- ME series
- MI-RM series (19")
- MT series
- MT-RM series (19")
- MTD
- MTD-RM

Online double-conversion (VFI)

- Securest UPS technology
- Protection against all types of disruption
- Stable output voltage
- No transform time
- Bypass function

Areas of application:

- Telecommunications
- Servers
- Measuring systems
- Medical equipment (not life-support)
- Critical industrial and IT applications

Models:

- MH / MH-RM series (19")
- MHD / MHD-RM series (19")
- MKD / MKD-RM series (19")
- Pegasus
- Quasar
- Quasar II

ME
ME



Line-interactive

400, 500, 600, 650, 800, 1000, 1500VA

The ME series offers as a succession model of the proven MI series reliable protection before current failures.

It was technically optimised and delivers optimum protection and improved communication possibilities for the electronic data processing with its digital circuit.

As a reasonable line-interactive model it is suitably for the application on pc's, workstations and network components.

Features

- UPS-Classification VI-SY-333 in accordance with IEC 62040-3
- Line-interactive technology
- Microprocessor-based regulation
- Automatic frequency synchronization
- Overload & short circuit protection
- RS-232, and SNMP via optional adapter
- optionally USB port
- Software-Suite PowerShut for UPS Management in almost all current operating systems
- 24 months' warranty

AC line-interactive UPS 400-3200VA



Rear view of ME 1000/1500



Rear view of ME 400-800VA
Models with USB



Rear view of ME 400-800VA
Models with RS232

Specifications

Model		ME 400	ME 500	ME 600	ME 650	ME 800	ME 1000	ME 1500	
Input	Voltage (VAC)	170-280VAC							
	Frequency (Hz)	50/60Hz							
	Synchronous zone	45-65Hz							
Output (AC-Mode)	AVR Regulation	Boost +13%							
		Buck -13%							
Output (INV.mode)	Voltage	230VAC							
		+/-15%				+/-10%		+/-15%	
	Frequency	50/60Hz±1%							
	Waveform	Modified sinewave							
	Capacity (VA/W)	400/225	500/250	600/300	650/325	800/425	1000/600	1500/900	
Battery	Transfer time (ms)	Typical 2-6ms						Typical 4ms	
	Autonomy at full load in min.	6	6	4	4	3	5	4	
	Voltage	12VDC	12VDC	12VDC	12VDC	12VDC	24VDC	24VDC	
	Type	Maintenance free lead acid							
DC start	Capacity	5Ah	7Ah	7Ah	7Ah	9.5Ah	7Ah	9.5Ah	
	Quantity	1	1	1	1	1	2	2	
	Recharging time	8 hours to 90%						6-8 hours to 90%	
Self diagnostics		Yes							
Indicator	LED	2 LEDs (AC mode, battery mode, fault)					4 LEDs: line, backup, fault, overload		
	Protection	Overload	AC mode INVmode				Buzzer warning and fuse will open		
Alarm	Short circuit	AC mode: input fuse and electronic circuit, Inv. Mode: electronic circuit							
	Noise suppression	EN50091-2					EN61000-4-5		
	Spike suppression	-							
	Battery over-drain	Battery low warning and UPS shut off							
	Modem / network	RJ45							
	Audible	Line failure, battery low					Line failure, battery low, overload/fault		
	Physical	Dimensions (HxWxD)	171x95x357mm						234x147x375mm
Environmental	Net weight	5.4kgs	5.8kgs	5.8kgs	5.8kgs	6.4kgs	10.6kgs	14.2kgs	
	Outlet (IEC)	3	3	3	3	3	6	6	
Communication	Operation temp.	0-40°C							
	Operation humidity	0-90% (non condensing)					0-95% (non condensing)		
Safety conformance	Interface type	RS232 SUB D 9 / optionally USB							
	Safety standard	EN50091-1							
Mark	EMC / surge standard	EN50091-2, EN61000-3-2, EN61000-3-3							
	Mark	CE							

MI RM



Line-interactive 600-1200VA

MI-Series is a cost-effective line-interactive system, that protects sensitive consumers from power blackouts.

Areas of application are computers and smaller servers and especially active network components in 19" switchboards.

- UPS-classification VI-SY-333 in accordance with IEC 62040-3
- Line-interactive technology
- Compact construction (only one 19" unit)
- Microprocessor-based regulation
- Automatic frequency synchronisation
- RS-232, opto-coupler and SNMP via adapter
- Software-Suite PowerShut for UPS Management in almost all current operating systems
- 24 months' warranty



MI 600 RM (rear view)



MI 1200 RM (rear view)

Specifications

Type	MI 600 RM	MI 1200 RM
Output		
Power VA/Watt	600/325	1200/720
Max current at 230 V (ampere)	2.6	5.3
Sockets	3 x nema sockets	3 x nema sockets
Output voltage	230V ± 10%	
Frequency	50/60Hz auto	
Waveform	Step wave	
Transfer time	Approx. 4 msec.	
Input		
Voltage	170-280VAC (230VAC)	
Frequency	50Hz (45-55) / 60Hz (55-65) auto	
Boost (+13%)	Yes	
Buck (-13%)	Yes	
Batteries		
Full load	5 min	5 min
DC voltage	12VDC	24VDC
Accumulators	7Ah-6V	7Ah-6V
Type	Lead-acid, maintenance-free (VRLA)	
Recharge time	8-10 hours up to 90%	
Efficiency AC-AC	>94%	
Auto-restart	Yes	
Audible noise	Noiseless	
Display		
LED (UPS Status)	Line, Batt, Fault	
Acoustic alert	Yes	
Protection		
Overload	Yes	
Lightning	ANSI/IEEE587 Class A	
EMC/LVD	EN50091-2, EN50091-1	
Certificates and tests	CE	
Communication	RS232 / opto-coupler / SNMP via adapter	
Environment		
Temperature	0-40°C (UPS without batteries)	
Humidity	0-95% (non-condensing)	
Mechanics		
Dimensions	1U x 19" x 245mm deep	1U x 19" x 350 mm deep
Weight	8.2kg	13.2kg

MTD-series

NEU / NEW



MTD 1000
left: front
right: rear view

Description

The MTD is EFFEKTA®'s further development of the line-interactive MT-series.

It protects sensitive consumers from power blackouts, spikes and other disruptions. Areas of application are computers, remote telecommunications and other computer-aided systems.

The unit's compact and stable construction has been complemented by a convenient LCD display for easier operation.

Features

- UPS-classification VFI-SS-311 in accordance with IEC 62040-3
- Line-interactive-technology
- User-friendly LCD-display
- Sine wave output
- Microprocessor controlled
- Automatic frequency detection
- Equipped with RS-232 port as standard
- Slot for optional adapters: relay-card, opto-coupler, USB or SNMP
- Software-Suite PowerShut for UPS Management in almost all current operating systems
- 36 months' warranty

Option: XL-Version with an possibility for easy extension of the autonomy time through external battery packs

Left picture: clear control panel with back lighted LCD display





MTD is equipped with RS-232 slot interface, which can be replaced with optional adapters: relay-card, opto-coupler, USB or SNMP.



Specifications

Model		MTD 1000	MTD 1500	MTD 2000
Power	Power in VA	1000	1500	2000
	Power in W	625	938	1250
Autonomy time	100% load	6min	6min	4min
	50% load	15min	15min	9min
Input	Nominal load	230VAC		
	Nominal input voltage	170-300VAC		
	Input frequency range	45-70Hz Auto Sensing		
	Boost starting value / shut-off	195.5VAC ± 2% / 205.5VAC ± 2%		
	Buck starting value / shut-off	264.5VAC ± 2% / 254.5VAC ± 2%		
	Undervoltage warning value / all-clear	170VAC ± 2% / 180VAC ± 2%		
	Overvoltage warning value / all-clear	300VAC ± 2% / 290VAC ± 2%		
Output	Output voltage	Adjustable on LCD-display 220, 230, 240VAC		
	Voltage tolerance	Line Mode	±15%	
		Battery Mode	<3% RMS	
	Frequency tolerance	Line Mode	50Hz oder 60Hz	
		Battery Mode	±0.1Hz	
	Power factor	0.625		
	Voltage form	Sine-wave		
	Efficiency	>80%		
DC start-up	black start	Yes		
Switch time	typical	<4msec.		
Battery	Nominal voltage	24VDC	36VDC	36VDC
	Blocks x nominal capacity / block	4 x 9Ah	3 x 9Ah	3 x 9Ah
	Type	Maintenance free sealed lead-acid battery		
	Life time	5 years, optional 10 years		
Recharge time	~5 h at 90%			
Display	LCD	UPS status, I/P&O/P Voltage & Frequency, Load %, Battery Voltage %, Temperature		
	LED	Normal (green) / Warning (yellow) / Fault (red)		
Audible alarm	Battery Mode	Beeping every 4 seconds		
	Battery Low	Beeping every second		
	fault	Beeping continuously		
	overload	Beeping twice per second		
Interface	Slot card	Standard with RS 232-interface		
		Optional cards: USB, relay, AS400, SNMP, Modbus		
Environment	Temperature	0°C – 40°C		
	Humidity	0-95% non-condensing		
	Operating height	<2000 above sea level		
	Acoustic Noise	<55dBA @ 1m		
Mechanic	Casing	Steel plate-tower / front plastic		
	Protection class	IP 20		
	Dimensions (H x W x D in mm)	210 x 145 x 380	210 x 145 x 445	210 x 145 x 445
Terminals	Weight	16.5kg	17.5kg	22.5kg
	Input	1 x IEC (10A)		
	Output	3 x IEC	6 x IEC	
Safety/Enclosure	DC-connection (for battery extension)	only XL-versions		
	Standards	EN62040-1-1		
	EMC	EN62040-2		
	Norms	CE		

MTD-RM series

NEU / NEW

1000, 1500, 2000VA
19" Rackmountable



upper model:
MTD 1000/1500 RM
bottom model:
MTD 2000 RM

Description

The MTD-RM is EFFEKTA®s' further development of the line-interactive MT-series.

It protects sensitive consumers from power blackouts, spikes and other disruptions. Areas of application are computers, remote telecommunications and other computer-aided systems.

The unit's compact and stable construction has been complemented by a convenient LCD display for easier operation.

Features

- UPS-classification VFI-SS-311 in accordance with IEC 62040-3
- Line-interactive-technology
- User-friendly LCD-display
- Compact design: only 1U (1000/1500 VA) and 2U (2000 VA)
- Sine wave output
- Automatic frequency detection
- Equipped with RS-232 port as standard
- Slot for optional adapters: relay-card, opto-coupler, USB or SNMP
- Software-Suite PowerShut for UPS Management in almost all current operating systems
- 36 months' warranty



Option: XL-Version with an possibility for easy extension of the autonomy time through external battery packs

Left picture: clearly arranged control panel with back lighted LCD display (2000 VA model)



MTD-RM is with its 1U (1000 and 1500VA, upper picture) and 2U (2000VA, bottom picture) one of the most compact 19" line-interactive UPS systems in this power stage.

MTD is equipped with RS-232 slot interface, which can be replaced with optional adapters: relay-card, opto-coupler, USB or SNMP.

Specifications

Model		MTD 1000 RM	MTD 1500 RM	MTD 2000 RM
Power	Power in VA	1000	1500	2000
	Power in W	625	938	1250
Autonomy time	100% load	3min	2min	4min
	50% load	8min	5min	9min
Input	Nominal load	230VAC		
	Nominal input voltage	170-300VAC		
	Input frequency range	45-70Hz Auto-Sensing		
	Boost starting value / shut-off	195.5VAC ± 2% / 205.5VAC ± 2%		
	Buck starting value / shut-off	264.5VAC ± 2% / 254.5VAC ± 2%		
	Undervoltage warning value / all-clear	170VAC ± 2% / 180VAC ± 2%		
	Overvoltage warning value / all-clear	300VAC ± 2% / 290VAC ± 2%		
Output	Output voltage	Adjustable on LCD Display 220, 230, 240VAC		
	Voltage tolerance	Line Mode	± 15%	
		Battery Mode	< 3% RMS	
	Frequency tolerance	Line Mode	50Hz or 60Hz	
		Battery Mode	± 0.1Hz	
	Power factor	0.625		
	Voltage form	Sine wave		
Efficiency	> 80%			
DC start-up	black start	Yes		
Switch time	typical	< 4msec.		
Battery	Nominal voltage	24VDC	24VDC	36VDC
	Blocks x nominal capacity / block	4 x 6V / 7Ah	4 x 6V / 7Ah	3 x 12V / 9Ah
	Type	Maintenance free sealed lead-acid battery		
	Life time	5 years, optional 10 years		
	Recharge time	5h at 90%		
Display	LCD	UPS status, I/P&O/P Voltage & Frequency, Load %, Battery Voltage %, Temperature		
	LED	Normal (green) / Warning (yellow) / Fault (red)		
Audible alarm	Battery Mode	Beeping every 4 seconds		
	Battery Low	Beeping every second		
	fault	Beep continuously		
	overload	Beeping twice per second		
Interface	Slot card	Standard with RS 232-interface. Optional cards: USB, relay, AS400, SNMP, Modbus		
	Environment	Temperature	0°C - 40°C	
Mechanic	Humidity	0-95% non-condensing		
	Operating height	< 2000m above sea level		
	Acoustic Noise	< 55dBA @ 1m		
	Casing	Steel plate-tower / front plastic		
Terminals	Protection class	IP 20		
	Dimensions (H x W x D in mm)	44 (1U) x 440 (19") x 515	44 (1U) x 440 (19") x 515	88 (2U) x 440 (19") x 465
	Weight	18kg	20.2kg	24.5kg
	Input	1 x IEC (10A)		
Safety/Enclosure	Output	3 x IEC	6 x IEC	
	DC-connection (for battery extension)	only XL-versions		
	Standards	EN62040-1-1		
Safety/Enclosure	EMC	EN62040-2		
	Norms	CE		

MT



Line-Interactive 700, 1000, 1500, 2000, 3200VA

The MT Series is a progressive line-interactive UPS, that protects sensitive consumers from power blackouts, spikes and other disruptions. Areas of application are computers, remote telecommunications and other computer-aided systems. The unit's compact and stable construction provides additional security and flexibility of use.

- UPS classification VI-SS-311 in accordance with IEC 62040-3
- Line-interactive technology
- Microprocessor-based regulation
- Pure sine wave output
- Temperature sensor
- Automatic frequency synchronisation
- RS-232, opto-coupler and SNMP via adapter
- Software-Suite PowerShut for UPS Management in almost all current operating systems
- 36 months' warranty



All models also available in black





MT 700 (rear view)



MT 1000-2000 (rear view)



MT 3200 (rear view)

Specifications

Type	MT 700	MT 1000	MT 1500	MT 2000	MT 3200
Output					
Power VA/Watt	700/470	1000/670	1500/1000	2000/1200	3200/2000
Max current at 230 V (ampere)	3.0	4.3	6	7.8	13.9
Sockets	2 x nema sockets	4 x nema sockets	4 x nema sockets	4 x nema sockets	6 x nema sockets
Output voltage	230V ± 3%				
Frequency	50/60Hz ± 0.1% auto				
Waveform	Pure sine wave				
Input					
Voltage	171-278VAC (230VAC)				
Frequency	50Hz (44-55) / 60Hz (55-65) auto				
Boost (+13%)	Yes				
Buck (-13%)	Yes				
Batteries					
Full load	8min	10min	10min	10min	8min
DC voltage	24VDC	36VDC	48VDC	60VDC	2x48VDC
Accumulators	7Ah-12V				
Type	Lead-acid, maintenance-free (VRLA)				
Recharge time	8-10 hours up to 90%				
Test	Automatic or test key				
Efficiency AC-AC	>95%				
DC-start-up (black-start)	Yes				
Auto-restart	Yes				
Overload	110% for 10sec.				
Audible noise	<40dB(A)				<45dB(A)
LED display					
UPS status	Line, On Bat, On AVR, Bat Weak, Fault, Overload, Load Level				
Acoustic alert	Yes				
Protection					
Overload	Yes				
Lightning	ANSI/IEEE587 Cat.A				
EMC/LVD	EN50091-2, EN50091-1				
Certificates and tests	CE				
Communication	black models optionally with RS232 + USB / opto-coupler / SNMP via adapter				
Environment					
Temperature	0-40°C (UPS without batteries)				
Humidity	0-95% (non-condensing)				
Mechanics					
Dimensions (HxWxD in mm)	160x120x360	200x160x450	200x160x450	200x160x450	290x160x530
Weight	13.3kg	19.5kg	22.6kg	26.2kg	45.0kg

MT RM



Line-interactive 700, 1000, 1500, 2000, 3200VA

The MT Series is a progressive line-interactive UPS, that protects sensitive consumers from power blackouts, spikes and other disruptions. Areas of application are computers, remote telecommunications and other computer-aided systems. The enclosures of the MT Series are almost the most robust and compact racks on the UPS market (starting from a 300mm mounting depth).

- UPS classification VI-SS-311 in accordance with IEC 62040-3
- Line-interactive technology
- Microprocessor-based regulation
- Pure sine wave output
- Temperature sensor
- Automatic frequency synchronisation
- RS-232, opto-coupler and SNMP via adapter
- Software-Suite PowerShut for UPS Management in almost all current operating systems
- 36 months' warranty



3200VA model

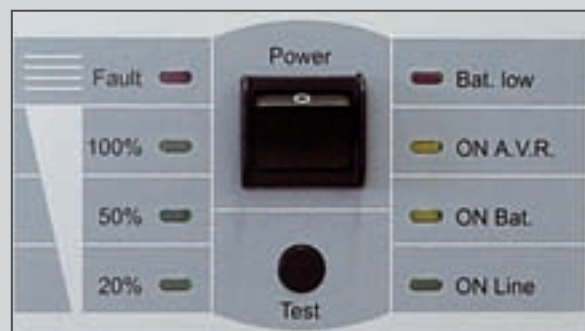



MT 700-1500 RM (rear view)



MT 2000 RM (rear view)



MT 3200 RM (rear view)

Specifications

Type	MT 700 RM	MT 1000 RM	MT 1500 RM	MT 2000 RM	MT 3200 RM
Output					
Power VA/Watt	700/450	1000/670	1500/1000	2000/1200	3200/2000
Max current at 230V (ampere)	3	4.3	6	7.8	13.9
Sockets	2 x three-core sockets	2 x three-core sockets	2 x three-core sockets	2 x three-core sockets	8 x nema sockets
Output voltage	230V ± 3%				
Frequency	50/60Hz ± 0.1% auto				
Waveform	Pure sine wave				
Input					
Voltage	171-278VAC (230VAC)				
Frequency	50Hz (45-55) / 60Hz (55-65) auto				
Boost (+13%)	Yes				
Buck (-13%)	Yes				
Batteries					
Full load	8min	10min	10min	10min	8min
DC voltage	24VDC	36VDC	48VDC	60VDC	2 x 48VDC
Accumulators	7Ah-12V				
Type	Lead-acid, maintenance-free (VRLA)				
Recharge time	8-10 up to 90%				
Test	Automatic or test key				
Efficiency AC-AC	>95%				
DC-start-up (black-start)	Yes				
Auto-Restart	Yes				
Overload	110% for 10sec.				
Audible noise	<35dB(A)				<45dB(A)
LED display					
UPS status	Line, On Bat, On AVR, Bat Weak, Fault, Overload, Load Level				
Acoustic alert	Yes				
Protection					
Overload	Yes				
Lightning	ANSI/IEEE587 Cat.A				
EMC/LVD	EN50091-2, EN50091-1				
Certificates and tests	CE				
Communication	RS232 / opto-coupler / SNMP via adapter				
Environment					
Temperature	0-40°C (UPS without batteries)				
Humidity	0-95% (non-condensing)				
Mechanics					
Dimensions (U x 19" x D in mm)	3U x 19" x 300	3U x 19" x 300	3U x 19" x 300	3U x 19" x 350	3U x 19" x 480
Weight	15kg	19.6kg	24kg	29.5kg	49.5kg

MKD



MKD 1000
To the right: Rear view
To the left: Front view

Description

The MKD UPS is a modern, microprocessor controlled online double-conversion UPS.

The MKD UPS features electronic bypass and is to be applied with supersensitive and critical applications like servers, workstations, metrological or industrial systems.



Features

- UPS-classification VFI-SS-111 (IEC 62040-3)
- Extraordinary wide voltage range (118-300VAC @ <50% load)
- User-friendly LCD-Panel
- Online double-conversion
- Sine wave output
- Microprocessor controlled
- Automatic frequency detection
- Equipped with RS-232 port as standard
- Slot for optional adapters: relay card, opto-coupler, USB or SNMP
- Software-Suite PowerShut for UPS Management in almost all current operating systems
- Optional XL-version with external battery cabinets
- 36 months' warranty

Left hand picture: 2000 VA XL-version with optional external battery cabinet (right hand casing)

AC online double-conversion UPS 700-3000VA



Rear view MKD 700/1000



Rear view MKD 2000



Rear view MKD 3000

Specifications

Type		MKD 700	MKD 1000	MKD 2000	MKD 3000
Power	Power in VA	700	1000	2000	3000
	Power in W	490	700	1400	2100
Autonomy time	Nominal load	10	7	7	6
Input	Nominal input voltage	230VAC			
	Input voltage range	118~300VAC (0-50% load), 140~300VAC (50-70% load), 160~300VAC (70-100% load)			
	Input frequency range	50 or 60Hz +/-8%			
	Max. input current	s. terminals > input fuse			
	Powerfactor (cos φ)	>0.95		>0.97	
Output	Output voltage	adjustable 220, 230, 240VAC			
	Deviation statically	+/-2%			
	Waveform	Sine wave			
	Output frequency	50 or 60Hz (synchronized line-mode / ± 0.5% battery mode)			
	Harmonic distortion / linear load	< 3% @ full load		< 4% @ full load	
	Crest factor acc. EN 50091-1	3:1 / (surge current / RMS-current)			
	Max. output current in A	3	4.3	8.7	13
	Efficiency at nom. Load	>85% AC-AC / >83% DC-AC			
Overload	Normal operation mode	Bypass transfer @ load > 110%			
	Normal / battery mode	105-150% for 30Sec. / 150% for 200mSec			
	Short circuit current	3 x Inenn for (120mSec)			
Bypass	Voltage range	Adjustment range min. 156-196V, max. 233-273V			
	Transfer time	2.5mSec inverter to bypass			
Battery	Nom. Voltage	36VDC	36VDC	96VDC	96VDC
	Blocks	3	3	8	8
	Nom. capacity/block	7Ah	7Ah	7Ah	7Ah
	Type	Lead acid, maintenance free batteries			
	Life time	App. 5 years (subject to environment)			
	Recharge time	App. 5h up to 90%			
Prot./standards	Battery test	Manually via button or via software			
	Appliances	Electron. overload- and short circuit-prot., temperature monitoring, deep discharge protection...			
	Safety	CE / EN62040-1			
	EMC	EN 62040-2			
Environment	Temperature (operational)	0°C – 40°C			
	Temperature (storage)	0°C – 40°C			
	Humidity	20-95% not condensing			
Mechanic	Altitude (operational)	<2000m o. NN			
	Casing	Steel plate / front plastics			
	Protection class	IP20			
	Dimensions (H x W x D in mm)	220x160x400	220x160x400	352x200x450	352x200x450
Terminals	Weight	15kgs	15kgs	34kgs	35kgs
	Input	1 x IEC (10A)			
	Output	4 x IEC		6 x IEC	
	Input fuse	6.3A	6.3A	10A	16A
	DC-terminals (for ext. battery extension)	Only XL-models			
Communication	Socket Sub-D 9, slot	RS 232-interface / Optionally available cards for slot: USB, relays, SNMP			

MKD-RM



Right hand picture:
MKD 2000/3000 RM

Description

The MKD UPS is a modern, microprocessor controlled online double-conversion UPS.

With its extraordinary compact design MKD RM can specially be used in racks with a minimum of space capacity.

The MKD UPS features an electronic bypass and is to be applied with supersensitive and critical applications like servers, workstations, metrological or industrial systems.



Bottom picture: MKD 700/1000 RM

Features

- UPS-classification VFI-SS-111 (IEC 62040-3)
- Extraordinary wide voltage range (118-300VAC @ <50% load)
- User-friendly LCD-Panel
- Compact design: only 2U per slot already from 415mm depth (700/1000VA)
- Online double-conversion
- Sine wave output
- Microprocessor controlled
- Automatic frequency detection
- Equipped with RS-232 port as standard
- Slot for optional adapters: relay card, opto-coupler, USB or SNMP
- Software-Suite PowerShut for UPS Management in almost all current operating systems
- Optional XL-version with external battery cabinets
- 36 months' warranty

AC online double-conversion UPS 700-3000VA



Rear view of MKD 700/1000 RM (internal batteries)



Rear view of MKD 2000 RM (electronics only)



Rear view of MKD 3000 RM (electronics only)



Rear view of battery pack for MKD 2000/3000 RM (same type for XL models)

Specifications

Type		MKD 700 RM	MKD 1000 RM	MKD 2000 RM	MKD 3000 RM
Power	Power in VA	700	1000	2000	3000
	Power in W	490	700	1400	2100
Autonomy time	Nominal load	10	7	7	6
Input	Nominal input voltage	230VAC			
	Input voltage range	118~300VAC (0-50% load), 140~300VAC (50-70% load), 160~300VAC (70-100% load)			
	Input frequency range	50 or 60Hz +/-8%			
	Max. input current	s. terminals > input fuse			
	Powerfactor (cos φ)	>0.95		>0.95	
Output	Output voltage	adjustable 220, 230, 240VAC			
	Deviation statically	+/-2%			
	Waveform	Sine wave			
	Output frequency	50 or 60Hz (synchronized line-mode / ± 0.5% battery mode)			
	Harmonic distortion / linear load	< 3% @ full load		< 3% @ full load	
	Crest factor acc. EN 50091-1	3:1 / (surge current / RMS-current)			
	Max. output current in A	3	3	3	3
	Efficiency at nom. Load	>85% AC-AC / >83% DC-AC			
Overload	Normal operation mode	Bypass transfer @ load > 110%			
	Normal / battery mode	105-150% for 30Sec. / 150% for 200mSec			
	Short circuit current	3 x Inenn for (120mSec)			
Bypass	Voltage range	Adjustment range min. 156-196V, max. 233-273V			
	Transfer time	2.5mSec inverter to bypass			
Battery	Nom. Voltage	36VDC	36VDC	96VDC	96VDC
	Blocks	3	3	8	8
	Nom. capacity/block	7Ah	7Ah	7Ah	7Ah
	Type	Lead acid, maintenance free batteries			
	Life time	App. 5 years (subject to environment)			
	Recharge time	App. 5h up to 90%			
Prot./standards	Battery test	Manually via button or via software			
	Appliances	Electron. overload- and short circuit-prot., temperature monitoring, deep discharge protection...			
	Safety	CE / EN62040-1			
	EMC	EN 62040-2			
Environment	Temperature (operational)	0°C – 40°C			
	Temperature (storage)	0°C – 40°C			
	Humidity	20-95% not condensing			
Mechanic	Altitude (operational)	<2000m o. NN			
	Casing	Steel plate / front plastics			
	Protection class	IP20			
	Dimensions (H x W x D in mm)	2U x 19" x 415mm	2U x 19" x 415mm	2 x 2U x 19" x 465mm	2 x 2U x 19" x 465mm
Terminals	Weight	15kgs	15kgs	34kgs	35kgs
	Input	1 x IEC (10A)			1 x IEC (16A)
	Output	4 x IEC		4 x IEC	2 x IEC (10A) 1 x IEC (16A)
	Input fuse	6.3A	6.3A	10A	16A
Communication	DC-terminals (for ext. battery extension)	optional			
	Socket Sub-D 9, slot	RS 232-interface / Optionally available cards for slot: USB, relays, SNMP			

MH
MH



Online double-conversion
700, 1000, 1500, 2000, 3000VA

The MH Series is a state of the art, microprocessor-controlled online double-conversion UPS solution with an electronic bypass for supersensitive and critical applications such as servers, workstations, and measuring or industrial machines.

- UPS-classification VFI-SS-111 in accordance with IEC 62040-3
- Online double-conversion
- Auto-select input frequency
- Pure sine wave output
- Microprocessor-based regulation
- Automatic frequency synchronisation
- Intelligent battery management
- RS-232, opto-coupler and SNMP via adapter
- Software-Suite PowerShut for UPS Management in almost all current operating systems
- Temperature sensor
- 36 months' warranty



MH 2000 display- "line-mode / 20% load"

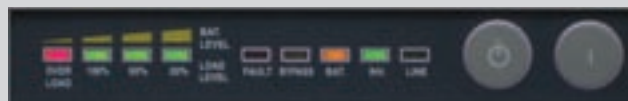

MH 2000 display- "battery-mode / batteries loaded"



MHD series with RS232
+ USB + LCD-Display

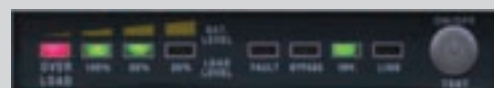

MH 700 display- "battery-mode /
batteries at 3/4 capacity"



MH 700-1500 (rear view)



MH 2000-3000 (rear view)

Specifications

Type	MH 700	MH 1000	MH 1500	MH 2000	MH 3000
Output					
Power VA/Watt	700/490	1000/700	1500/975	2000/1400	3000/2100
Max current at 230V	3.0A	4.3A	6A	8.7A	13A
Sockets	2 x three-core sockets	2 x three-core sockets	2 x three-core sockets	3 x three-core sockets	3 x three-core sockets
Output voltage	230V ± 2%				
Frequency	50/60Hz ± 0.1% auto				
Waveform	Pure sine wave				
Input					
Voltage	160-275VAC (230VAC)				
Frequency	45-65Hz				
Batteries					
Full load	10min	10min	6min	10min	10min
DC-voltage	24VDC	36VDC	36VDC	72VDC	96VDC
Accumulators	7Ah-12V		7/9.5Ah-12V	7Ah-12V	
Type	Lead-acid, maintenance-free (VRLA)				
Recharge time	8-10 up to 90%				
Test	Automatic or test key				
PFC	Yes				
Efficiency AC-AC	>85%				
DC-start-up (black-start)	Yes				
Auto-restart	Yes				
Overload	110% for 10-25sec.				
Audible noise	<45dB(A)		<50dB(A)	<47dB(A)	
LED display					
USV status	LINE; BYPASS; INV; FAULT; BAT-LEVEL; LOAD-LEVEL; BAT.(MH 2000/3000)				
Load status	20%, 50%, 100%, OVERLOAD				
Audible alert	Yes				
Protection					
Overload	Yes				
Lightning	ANSI/IEEE587 Cat.A				
EMC/LVD	EN50091-2, EN50091-1				
Certificates and tests	CE				
Communication	RS232 / opto-coupler / SNMP via adapter / MHD Series with RS232 + USB + LCD-Display (black cabinet)				
Environment					
Temperature	0-40°C (UPS without batteries)				
Humidity	0-95% (non-condensing)				
Mechanics					
Dimensions (HxWxD in mm)	190x140x440	190x140x440	190x140x440	320x190x500	320x190x500
Weight	12.5kg	15kg	15.2kg	32.4kg	38.2kg

MH RM



MH 2000-3000 RM incl. battery cabinet

Online double-conversion 19" 700, 1000, 1500, 2000, 3000VA

The MH RM is a state of the art, microprocessor-controlled online double-conversion solution with an electronic bypass for supersensitive and critical application such as servers, workstations and measuring or industrial machines. The enclosures of this series are amongst the most robust and compact racks on the UPS market (starting from a 390mm mounting depth).

- UPS-classification VFI-SS-111 according IEC 62040-3
- Online-Double conversion
- Auto select input frequency
- Pure sine wave output
- Microprocessor based regulation
- Automatic frequency synchronisation
- Intelligent battery management
- RS-232, opto-coupler and SNMP via Adapter
- Software-Suite PowerShut for UPS Managemnt in almost all current operating systems
- Temperature sensor
- 36 months warranty



MH 2000 display- "line-mode / 20% load"

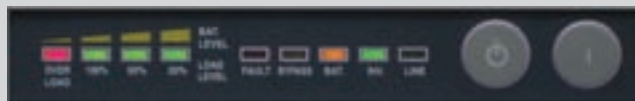

MH 2000 display- "battery-mode / batteries loaded"

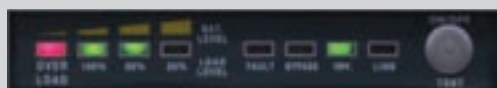

MH 700 display- "battery-mode / batteries at 3/4 capacity"



MHD-RM series with RS232
+ USB + LCD-Display

AC online double-conversion UPS 700-3000VA



MH 700-1500 RM (front view)



MH 700-1500 RM (rear view)



Battery cable



MH 2000-3000 RM (with battery cabinet) (rear view)

Specifications

Type	MH 700 RM	MH 1000 RM	MH 1500 RM	MH 2000 RM	MH 3000 RM
Output					
Power VA/Watt	700/490	1000/700	1500/975	2000/1400	3000/2100
Max current at 230V	3.0A	4.3A	6A	8.7A	13A
Sockets	2x three-core sockets	2x three-core sockets	2x three-core sockets	2x three-core sockets	2x three-core sockets
Output voltage	230V ± 2%				
Frequency	50/60Hz ± 0.1% auto				
Waveform	Pure sine wave				
Input					
Voltage	160-275VAC (230VAC)				
Frequency	45-65Hz				
Batteries					
Full load	10min	10min	min	10min	10min
DC voltage	24VDC	36VDC	36VDC	72VDC	96VDC
Accumulators	7Ah-12V	7Ah-12V	9.5Ah-12V	7Ah-12V	7Ah-12V
Type	Lead-acid, maintenance-free (VRLA)				
Recharge time	8-10 hours up to 90%				
Test	Automatic or test key				
PFC	Yes				
Efficiency AC-AC	>85%				
DC-start-up (black-start)	Yes				
Auto Restart	Yes				
Overload	110% for 10-25sec.				
Audible noise	< 45dB(A)		< 50dB(A)		< 45dB(A)
LED display					
UPS status	LINE; BYPASS; INV; FAULT; BAT-LEVEL; LOAD LEVEL; BAT.(MH 2000/3000)				
Load status	20%, 50%, 100%, OVERLOAD				
Audible alert	Yes				
Protection					
Overload	Yes				
Lightning	ANSI/IEEE587 Cat.A				
EMC/LVD	EN50091-2, EN50091-1				
Certificates and tests	CE				
Communication	RS232 / opto-coupler / SNMP via adapter				
Environment					
Temperature	0-40°C (UPS without batteries)				
Humidity	0-95% (non-condensing)				
Mechanics					
Dimensions (U x 19" x D in mm)	2U x 19" x 390	2U x 19" x 390	2U x 19" x 420	2U x 19" x 480	2U x 19" x 480
Weight	16.4kg	19.3kg	19.7kg	15.4kg	15.5kg
Dimensions battery-pack (U x W x D in mm)	-	-	-	2U x 19" x 395	2U x 19" x 395
Weight battery-pack	-	-	-	25.4kg	31kg

MH 6000



MH 6000 incl battery cabinet

Online double-conversion 6000VA with 1-phase input

MH 6000 is a progressive development of UPS MH 5000/7000. With its fast DSP (Digital Signal Processing) controller it offers a new sine-wave quality and high performance in controlling input & output. Digitalisation of all circuits accelerates, optimises and reduces the number of components and increases the standard lifetime of important parts.

The reliability and availability of the power line has been improved considerably compared to existing switching technologies.

A wide range of easy-to-use extension options enable the UPS to be integrated easily for any application. Its modern design, compact dimensions and low audible noise make it suitable for all kinds of offices.

- UPS-classification VFI-SS-111 in accordance with IEC 62040-3
 - True Online-Double conversion
 - Digital control processor
 - Dual input loops
 - Smart eco mode
 - Programmable frequency processor
 - Easy-to-set user personalization
 - Power range and runtime scalability
 - RS-232 + EPO (equipped as standard)
 - Additional slot for optional relaycard or SNMP-adapter
 - Management software enclosed
 - 24 months' warranty
-
- Optional easy-to-use parallel installation
 - Optional galvanic isolation transformer
 - Optional hot swappable batteries



MH 6000 Display



MH 6000 (rear view)



MH 6000 (adapter slot)

Specifications

Type	MH 6000
Power	
VA Rating	6000
Wattage	4200
Cos phi	0.7
Input	
Voltage	160-280VAC
Frequency	45-65Hz
Current in Ampere	25
PFC (power-factor-correction)	yes
Output	
Voltage	200/220/230/240VAC selectable, ± 2%
Current in Ampere	21
Overload	110% for 125 sec./140% for 10sec. - 2 cycles before switching to bypass
Frequency	50/60Hz (± 0.2Hz in backup mode)
Waveform	Pure sine wave
Crest factor	3:1
Harmonic distortion	<3% with linear load
Fault reaction	Automatic switch to bypass or disconnection (in case of overload, overheat or short circuit)
Efficiency	up to 91% / in eco mode up to 98%
BatterIES	
Autonomy time (100% load)	>8min.
DC-voltage	240VDC
Number of blocs	20
Capacity per unit	7Ah
Type	Lead acid, maintenance free (VRLA)
Expected lifetime	5 years (optional 10 years)
Recharge time	<4 hours up to 90%
Bypass (SBS)	
Nominal voltage	1 x 230V (160-280V)
Overload	200% for 160msec.
Manuel bypass (standard)	Yes
Communication	
Display	Status on LCD + LCD: Line Mode, Backup Mode, ECO Mode, Bypass supply, Battery Low, Battery Bad/Disconnected, Overload, Transferring with Interruption & UPS Fault Readings on LCD: Input Voltage, Input Frequency, Output Voltage, Output Frequency, Load percentage, Battery Voltage & Inner Temperature
Alarms	Audible and visual: Line Failure, Battery Low, Transfer to Bypass, System Fault Condition
Interface	Standard RS232 interface, Communication slots options: 2nd RS232 & EPO, USB & EPO, RS 485 & EPO, Relay contact & EPO, SNMP/WEBcard, etc.
SNMP	Optional via software or external/slot adaptor
Certificates and tests	
Security	IEC 950/EN 50091-1, CE
EMV / RFI	EN 55022 « A »
Mechanics / Environment	
Casing	Tower / colour black / protection type IP 21 / 748 x 290 x 645mm (H x W x D) / app. 86kg
Temperature	0-40°C (UPS without battery)
Humidity	10-90% (non condensing)
Audible noise	55dB(A) in 1m distance (depends on load and temperature)

MH 6000 RM



6000VA online double-conversion with single-phase output

MH 6000 RM is a fully digital UPS from EFFEKTA®. With its fast DSP (Digital Signal Processing) controller it offers a new sine-wave quality and high performances in controlling input and output.

Digitalisation of all circuits accelerates, optimises and reduces the number of components and increases the standard lifetime of important parts.

The reliability and availability of the power line has been improved considerably compared to existing switching technologies.

A wide range of easy-to-use extensions enable the UPS to be integrated easily for any application.

- UPS-classification VFI-SS-111 in accordance with IEC 62040-3
- True online double-conversion
- Digital control processor
- LCD display, 30 different status messages
- Sine wave current consumption
- Pure sine wave output
- Digital battery management
- Modular battery extension
- RS-232 + EPO (equipped as standard)
- Additional slot for optional relaycard or SNMP-adaptor
- Management software enclosed
- 24 months' warranty

- Optional external bypass



External bypass with optional web manager



rear view:
Electronic-module at top,
battery cabinet middle
and bottom

Specifications

Type	MH 6000 RM
Power	
VA Rating	6000
Wattage	4200
Cos phi	0.7
Input	
Voltage	160-280VAC
Frequency	45-65Hz
Current in Ampere	25
PFC (power-factor-correction)	yes
Output	
Voltage	200/220/240VAC selectable, $\pm 2\%$
Current in Ampere	21
Overload	<105% : 160 s >105% ... < 150% : 40ms >150% : immediately
Frequency	50/60Hz (± 0.2 Hz in backup mode)
Waveform	Pure sine wave
Crest factor	3:1
Harmonic distortion	<3% with linear load
Fault reaction	Automatic switch to bypass or disconnection (in case of overload, overheat or short circuit)
Efficiency	up to 91% / in eco mode up to 98%
BatterIES	
Autonomy time (100% load)	>8min.
DC-voltage	240VDC
Number of blocs	20
Capacity per unit	9,5Ah
Type	Lead acid, maintenance free (VRLA)
Expected lifetime	5 years (optional 10 years)
Recharge time	<8 hours up to 90%
Bypass (SBS)	
Nominal voltage	1 x 230V (160-280V)
Overload	200% for 160msec.
Manuel bypass (standard)	Yes
Communication	
Display	Status on LCD + LCD: Line Mode, Backup Mode, ECO Mode, Bypass supply, Battery Low, Battery Bad/Disconnected, Overload, Transferring with Interruption & UPS Fault Readings on LCD: Input Voltage, Input Frequency, Output Voltage, Output Frequency, Load percentage, Battery Voltage & Inner Temperature
Alarms	Audible and visual: Line Failure, Battery Low, Transfer to Bypass, System Fault Condition
Interface	Standard RS232 interface Communication slots options: 2nd RS232 & EPO, USB & EPO, RS 485 & EPO, Relay contact & EPO, SNMP/WEBcard, etc. Optional via software or external/slot adaptor
SNMP	
Certificates and tests	
Security	IEC 950/EN 50091-1, CE
EMV / RFI	EN 55022 « A »
Mechanics / Environment	
Casing	19" rack mountable / colour black / protection type
Dimensions UPS (H x W x D in mm)	3U / 19" / 545mm
Dimensions battery pack (H x W x D in mm)	2 x (2U / 19" / 515mm)
Weight	19.5 + 36.5 + 36.5
Temperature	0-40°C (UPS without battery)
Humidity	10-90% (non condensing)
Audible noise	50dB(A) in 1m distance (depends on load and temperature)

MHD 10-20kVA



**Online double-conversion 10-20kVA
with 1-phase (10kVA) input
or 3-phase (10, 15, 20kVA) input**

The MHD 10-20kVA with its fast DSP (Digital Signal Processing) controller offers a new sine-wave quality and high performance in controlling input & output. Digitalisation of all circuits accelerates, optimises and reduces the number of components and increases the standard lifetime of important parts.

The reliability and availability of the power line has been improved considerably compared to existing switching technologies.

A wide range of easy-to-use extension options enable the UPS to be integrated easily for any application. Its modern design and compact dimensions make it suitable for all kinds of offices.

Features & Advantages

- UPS-classification VFI-SS-111 (IEC 62040-3)
- Online Double-Conversion
- Multiple Microprocessor design base
- Detachable control panel with LCD
- Wide input voltage range
- Optionally parallel design
- DC start and automatic self-diagnostic function
- High capacity of battery through extension packs
- Slot for alternatively RS232, SNMP or relay card
- High efficiency design
- Low heat dissipation in long term operation
- 24 months' warranty



MHD 10kVA display



UPS electronics rear view

Specifications

Model		MHD 10kVA 1-1	MHD 10kVA 3-1	MHD 15 kVA 3-1	MHD 20kVA 3-1
Capacity		10KVA/7KW	10 kVA/7kW	15kVA/10,5kW	20kVA/14kW
Input	Nominal Voltage	Single ph. 230Vac	3 ph. 380Vac		
	Voltage Range	176-276Vac	304-478Vac		
	Frequency	50Hz or 60Hz +/- 8%			
	Power Factor	≥0.98	≥0.95		
Output	Voltage	220 / 230 / 240Vac +/- 1%			
	Frequency	Synchronized (Line mode), 50Hz or 60Hz +/- 0.5Hz (Battery Mode)			
	Wave-form	True Sine wave			
	Distortion	2% (Linear Load), 6% (Non-Linear Load)			
	Crest Ratio	3:1			
Battery	Type	Maintenance free sealed lead-acid battery			
	Capacity	12V / 9Ah * 20pcs	On request	On request	On request
	Back-up	4min	On request	On request	On request
	Built-In Charger	2A	4,2A	4,2A	4,2A
	Charger (Option)	4.2A	On request	On request	On request
	Charging Voltage	274Vdc +/- 0.5V	On request	On request	On request
	Recharger Time	7-8 hrs to 90% of full capacity after full load discharge			
Transfer Time	AC-DC to Bypass	0 ms			
Indicator Removable	LCD	UPS status, I/P&O/P Voltage & Frequency, Load %, Battery Voltage & %, Temperature, Model Spec., Event Log			
	LED	Normal (Green), Warning (Yellow), Fault (Red)			
Audible Alarm	Battery Mode	Beeping every 4 seconds			
	Battery Low	Beeping every seconds			
	Overload	Beeping twice per second			
	Fault	Beep Continuously			
Interface	RS-232 Interface	Yes			
	SNMP Intelligent Slot (Option)	Power management via optional SNMP management and web browser			
Certificates	engineer standards	CE			
Environment	Temperature	0-40 degree C; 32-104 degree F			
	Humidity	20-90% non-condensing			
	Acoustic Noise (at 1M)	< 55dBA	< 55dBA	< 60dBA	< 60dBA
Weight	w/ battery	94kgs	Batteries on principle in external cabinet		
	w/o battery	38kgs	38,5kgs	55kgs	55kgs
Dimension	(HxWxD)mm	717x260x570	717x260x570	717x260x570	717x260x570

MHD RM 10kVA

NEU / NEW

Right hand picture:
Front view
MHD RM 10kVA incl.
battery cabinet



19"-online double-conversion UPS 10.000VA with 1-phase input

The MHD 10 RM offers a new sine-wave quality and high performance in controlling input & output with its modern electronics.

The depth of only 570 mm is one of the smallest on the UPS market. This compactness and the other advantages make the MHD 10 RM suitable for all applications, that presuppose highest reliability and minimal required space of the UPS system.

The reliability and availability of the power line has been improved considerably compared to existing switching technologies.

A wide range of easy-to-use extension options enable the UPS to be easily dimensioned and professionally integrated for any application.

Bottom picture: optionally external bypass



Features

- UPS-classification VFI-SS-111 (IEC 62040-3)
- Online double-conversion with sine-wave output
- Compact design with 19" width, 4U (electronics), and only 570 mm depth
- User-friendly LCD-Panel
- Microprocessor controlled
- Wide voltage range
- Sine wave current consumption
- DC start and automatic self-diagnostic function
- Modular battery extension
- RS-232 (equipped slot as standard)
- Slot for optional relaycard, USB or SNMP-adapter
- High efficiency design
- Low heat dissipation in long term operation
- 24 months' warranty



MHD 10 RM display



rear view

Specifications

Model		MHD 10 RM
Capacity		10kVA / 7kW
Input	Nominal Voltage	1-ph. 230VAC (L, N, P)
	Voltage Range	176-276VAC
	Frequency	50 or 60Hz ± 8%
	Power Factor	≥ 0,98
Output	Voltage	220 / 230 / 240VAC ± 1%
	Frequency	Synchronized (Line mode), 50Hz or 60Hz ± 1% (Battery Mode)
	Wave-form	Sine-wave
	Distortion	< 2% (Linear load), < 6% (non-linear load)
	Crest Ratio	3:1
Battery	Type	Maintenance free sealed lead-acid battery
	Capacity	12V, 9Ah
	Back-up	4min, extendible
	Built-In Charger	2A
	Charging Voltage	274VDC ± 0,5V
Recharging Time	7-8h at 90% of full capacity after full load discharge	
Transfer Time	AC-DC to Bypass	0ms
Indicator	LCD	UPS status, I/P&O/P Voltage & Frequency, Load %, Battery Voltage %, Temperature Model Spec., Event Log
	LED	Normal (green), Warning (yellow), Fault (red)
Audible Alarm	Battery Mode	Beeping every 4 seconds
	Battery Low	Beeping every second
	Overload	Beeping twice per second
	Fault	Beep Continuously
Interface	RS-232 interface	yes
	Options	USB
		SNMP
Environment	Temperature	0-40°C; 32-104°F
	Humidity	20-90% non-condensing
	Operating height	0 .. 5000m
		if operating above 1000m it is important to reduce load
Weight	Acoustic Noise (at 1M)	< 57dBA
	w/battery (standard)	101kg
	w/o battery	27kg
Dimension	UPS electronics	4U x 19" x 570mm incl. terminals
	Battery cabinet	2 x 2U x 19" x 515mm (570mm incl. terminals)

QUASAR II

NEU / NEW

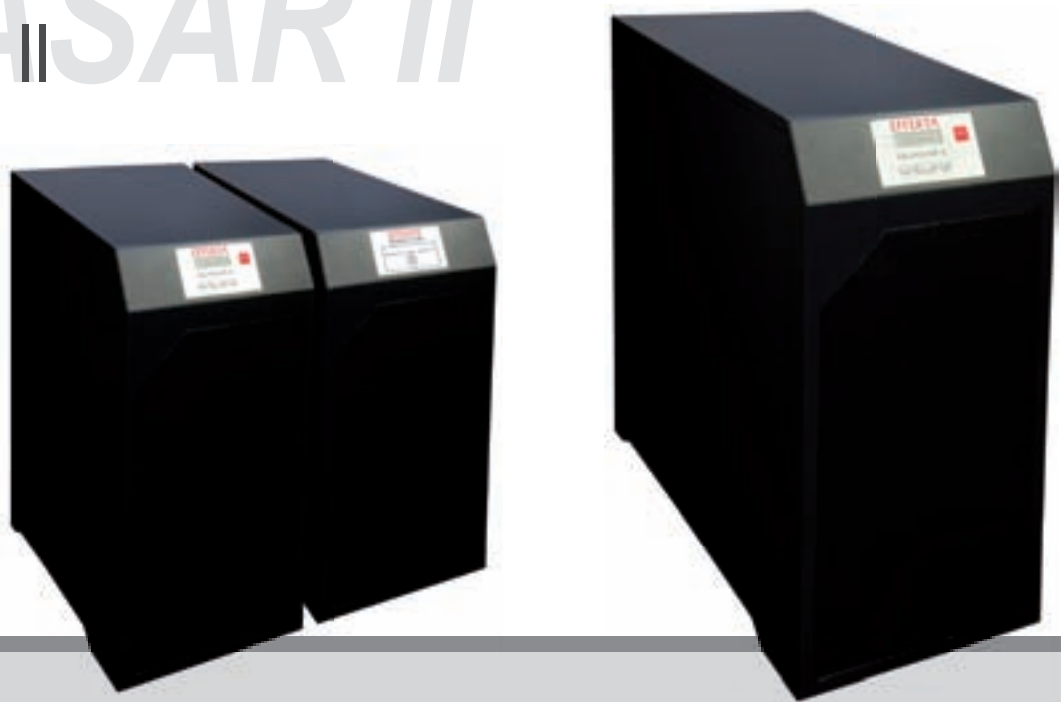

Online double-conversion 10, 15, 20, 25, 30kVA

As one of the first UPS on the market, QUASAR II from EFFEKTA® can be programmed on every required phase configuration via software:

Selective:

1-phase input and 1-phase output

1-phase input and 3-phase output

3-phase input and 1-phase output

3-phase input and 3-phase output

Particularly, the configuration of 1-phase input and 3-phase output is unique on the UPS market.

The usage of IGBT-rectifiers reduces the distortion of the connected mains. The current consumption is almost ideal sinus and the power factor is increased compared with traditional thyristor designed UPS.

Considerable and comfortable extension possibilities simplify the dimensioning and professional involvement of the installation in any environment. Amongst others, several systems can be switched in parallel, to increase the reliability through redundant operation.

Features

- UPS-classification VFI-SS-111 in accordance with IEC 62040-3
- Online double-conversion with sine-wave output
- IGBT-rectifier
- Comfortable front control panel incl. EPO
- Interface for EPO remote control
- Space-saving cable feeding from the bottom of the housing
- Small dimensions
(all models 910 x 390 x 900 mm)
- Expandable autonomy time
- 24 months' warranty

Options:

- Parallel configuration
- Power extension
- Output isolating transformer
- Slot for optional adapter: relay-card or SNMP

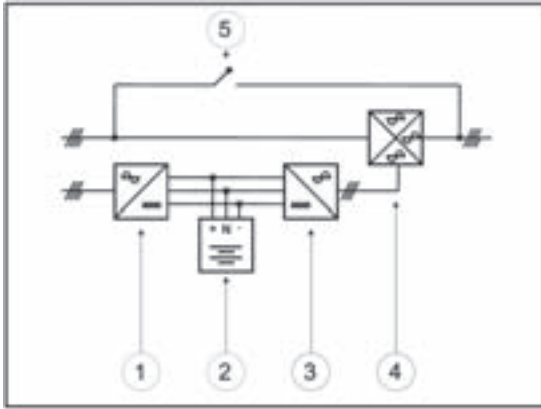

block diagram:

1. IGBT power input
2. Battery
3. Inverter power IGBT
4. Static Switch
5. Manual Bypass



Control panel: Quasar II has a clear control panel, in which the EPO switch is already integrated.

Specifications

Model		QUASAR II 10kVA	QUASAR II 15kVA	QUASAR II 20kVA	QUASAR II 25kVA	QUASAR II 30kVA
Power		10kVA / 8kW	15kVA / 12kW	20kVA / 16kW	25kVA / 20kW	30kVA / 24kW
Efficiency (AC-AC) - % (ECO-mode)		> 98%				
Efficiency (AC-AC) - % (Online-mode)		> 93% (@ 75% load)				
Input	Voltage nominal	Programmable on 3- or 1-phase: 3-ph. 380VAC / 1-ph. 230VAC				
	Voltage tolerance	380-415VAC ± 10VAC				
	Frequency	50Hz / 60Hz adjustable				
	Power Factor	0.8				
Output	Voltage	Programmable on 3- or 1-phase: 3-ph. 380/400/415VAC / 1-ph. 220/230/240VAC				
	Frequency	50/60Hz ± 0.005Hz (battery mode) ± 1Hz synchronized (line mode)				
	Voltage form	Sinus-wave				
	Distortion	< 3% (linear load), 5% (nonlinear load), in accordance with IEC 62040-3				
	Crest factor	3:1				
Batteries	Type	Maintenance free sealed lead-acid battery				
	Capacity	Internal 60 x 5Ah, 7Ah or 9Ah				
	Autonomy	10 minutes by nominal load / expandable				
	Voltage nominal	720VDC				
	Min. discharge voltage	600VDC				
	Charging voltage	810VDC				
	Charging time	7-8h at 90% of total capacity after complete discharge				
Transfertime	AC-DC to bypass	<1ms				
Display	LCD	Alphanumeric display				
	LED	Normal operation / alarm				
Acoustic alarm	Restable	Yes				
Interface	RS-232 Interface	Yes				
	SNMP (optional)	Powermanagement via optional SNMP-Adapter and Webbrowser				
	Relay contacts (optional)	4 signals via additional expansion card				
Environment	Temperature	0-40°C (battery 20- +30°C)				
	Humidity	< 90% non condensing				
	Audible noise @ 1m distance)	< 58dBA				
Weight	Without batteries	60kg	60kg	65kg	65kg	65kg
	Incl. batteries	230kg	230kg	230kg	230kg	230kg
Dimensions	HxWxD in mm	910 x 390 x 900	910 x 390 x 900	910 x 390 x 900	910 x 390 x 900	910 x 390 x 900
Safety		EN 50091-2, CEI-EN 62040-1-1, CEI EN 62040-1-2, CEI EN 62040-2, CEI EN 62040-3, CE				
Enclosure		IP20				
Colour		anthracite RAL 7016				

Quasar 60-120



Online double-conversion, 60-120kVA, with 3-phase input, 3-phase output

The UPS Quasar 60-120kVA is a progressive development of UPS Quasar 10-40kVA version.

The Quasar enables a reliable and uninterruptible power line. It is a double-conversion unit for supersensitive industrial and IT applications current available.

Up to 6 systems can be connected in parallel for redundant operations (n+1 operation) or for power increase.

- UPS-classification VFI-SS-111 in accordance with IEC 62040-3
- Online double-conversion
- Input power factor 0.95
- Sine wave current consumption
- 100% asymmetric load (>10s)
- 2 separate infeeds
- Wide input voltage range
- "Power save" mode
- Automatic and manual bypass
- Modular battery extension
- Menu-controlled LCD display
- Fully front-operable
- RS-232, communication and SNMP via adapter
- 24 months' warranty
- N+1 redundancy (optional)



Specifications

Power (in kVA)	Autonomy time in min. (more info on request)	UPS dimensions (H x W x D in mm)	battery cabinet dimensions (H x W x D in mm)	Weight in kg
60	10	1800x700x740	1220x770x950	300+915
	14	1800x700x740	1220x770x950	300+980
	20	1800x700x740	1800x911x800	300+1192
	35	1800x700x740	1800x1211x800	300+1741
80	5	1800x700x740	1220x770x950	335+915
	9	1800x700x740	1220x770x950	335+980
	13	1800x700x740	1800x911x800	335+1171
	25	1800x700x740	1800x1211x800	335+1713
100	5	1800x700x740	1220x770x950	365+980
	9	1800x700x740	1220x770x950	365+1171
	16	1800x700x740	1800x1211x800	365+1713
	25	1800x700x740	1800x2411x800	365+2654
120	5	1800x700x740	1800x911x800	455+1466
	9	1800x700x740	1800x911x800	455+1466
	16	1800x700x740	1800x1211x800	455+2143
	27	1800x700x740	1800x1811x800	455+3069

Type	Q060	Q080	Q100	Q120
Power				
Power in kVA/kW	60/48	80/64	100/80	120/96
Input power factor cos phi	0.95			
Input				
Voltage	3 x 380/400/415VAC (300+480VAC)			
Frequency	50/60Hz (40+70Hz)			
Input power factor correction	Yes			
Output				
Voltage	3 x 380/400/415VAC			
Current in ampere	87	115	144	174
Regulation - static	< 1%			
Regulation - dynamic (100% load fluctuation)	< 6%			
Overload inverter	125% for 10 minutes / 150% for 10 seconds			
Overload static bypass	150% für 30 minutes / 1000% für 0.1 seconds			
Frequency	50/60Hz (± 0.005% in backup mode)			
Synchronisation-range	± 1% to ± 4% selectable			
Waveform	Sine wave			
Crestfactor	3:1			
Harmonic distortion	<3% with linear load			
Fault reaction	Auto bypass mode / switch-off in case of overload, over-temp., short circuit			
Efficiency (battery full / 100% load)	>92%	>92.5%	>93%	>93.8%
Batteries				
Max. charging current in ampere (adjustable)	32	32	32	40
Nominal voltage	384VDC	384VDC	384VDC	480VDC
Number of 12V blocks	32	32	32	40
Capacity of each block	65-200Ah			
Type	VRLA			
Expected lifetime	10 years			
Recharging time	8 hours 80% capacity			
Bypass (EUE)				
Nominal voltage	380/400/415V			
Overload capacity	10 x Inom 100msec/ 1.5 x Inom 30min			
Manual bypass (standard)	Yes			
Interface communication				
Display	LCD display with 21 alphanumeric / status messages			
Acoustic alert	Yes			
Interface	RS232 / relay contacts for 4 condition information			
SNMP	Optional via software and adapter			
Certificates & tests				
EMC	CE			
Standards	EN50091-2, class A, IEC801-2, IEC801-3, IEC801-4 IEC 146-4, EN50091-1, IEC 950			
Mechanics / environment				
Enclosure	Tower / Protection IP 20 (IEC529, IEC944)			
UPS dimension (H x W x D in mm)	1800x700x740			
Battery pack dimensions (H x W x D in mm)	Depends on battery capacity			
Weight in kg (UPS without batteries)	400	470	500	540
Ambient temperature	0-40°C (UPS without battery)			
Rel. air humidity	<95% non-condensing			
Audible noise at 1m distance	<60dB(A) (depends on load and temperature)		<65dB(A) (depends on load and temperature)	

Pegasus 10-40kVA

10-20 kVA 3/1-phase

10-40 kVA 3/3-phase



Online double-conversion 10, 15, 20, 30, 40kVA

The PEGASUS is a online double-conversion UPS system with 1- or 3-phase output. It can be configured parallel-redundant. Up to 6 Systems can be connected in parallel for redundant operations and increases the availability.

The electronic components are up to highest standards as known from military requirements. So you find an UPS system with enhanced reliability, availability and safety.

The PEGASUS 10-40kVA is an UPS system with modular design. Each power module offers complete self-diagnosis to simplify the “on field” trouble-shooting.

The usage of IGBT rectifiers reduces the distortion of dependened mains. The current drain is almost ideal sinus and the power factor was increased in comparance to traditional thyristor design.

- UPS classification VFI-SS111 in accordance with IEC 62040-3
- Online double-conversion
- IGBT rectifier
- Input power factor >0,99
- Modular technology
- Models with 1- or 3 phase output available
- Modules with progressive self diagnostics
- High efficiency
- Output sine wave
- Digital control
- Comfortable LCD display
- Compact design
- Low weight
- RS-232 (equipped as standard)
- Additional slot for optional relaycard, RS485- or SNMP-adapter
- 24 months' warranty

- Optionally incl. BACS battery management
- Optionally up to 6 devices parallel
- Optionally external battery extension

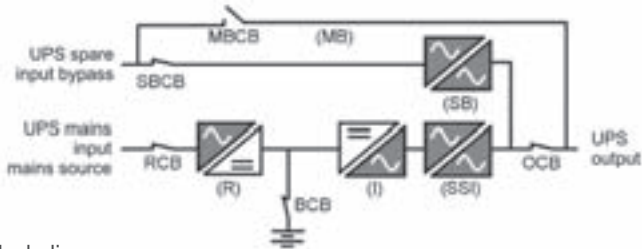

block diagram



control panel



UPS electronics (modular design / power module)

Specifications

Model	PEGASUS 10kVA 31/33	PEGASUS 15kVA 31/33	PEGASUS 20kVA 31/33	PEGASUS 30kVA 33	PEGASUS 40kVA 33
Power	10kVA / 8kW	15kVA / 12kW	20kVA / 16kW	30kVA / 24kW	40kVA / 32kW
Efficiency % (ECO-Mode)	>98	>98	>98	>98	>98
Efficiency (AC-AC) - % (Online-Mode)	>92	>92	>92	>92	>92
Input	Voltage nominal 3-ph. 400VAC				
	Voltage tolerance 380-400-415VAC +10% / -20%				
	Frequency 50Hz – 60Hz +/- 5Hz				
	Power factor >0.99				
Output	Voltage 31ph model: 220, 230, 240 selectable / 33ph model: 380-4 5VAC selectable				
	Frequency 50Hz or 60Hz +/- 0.001Hz (battery mode) +/- 2Hz synchronised (line mode)				
	Waveform Sinus				
	Distortion < 1% (linear load), 5% (nonlinear load), in accordance with IEC 62040-3				
	Crest factor 3:1				
Batteries	Type maintenance free lead acid batteries				
	Capacity	on request	on request	on request	on request
	Autonomy	on request	on request	on request	on request
	Voltage nominal	2 x 360VDC @ 25°C			
	Charging voltage	on request	on request	on request	on request
	Recharging time	7-8h 90% capacity			
Transfertime	AC-DC to bypass 0ms				
Display	LCD Alphanumeric backlit display				
	LED Diagramm with LEDs				
Acoustic alarm	Restable Yes				
Interface	RS-232 interface Yes				
	SNMP (Option) Powermanagement via optional SNMP-Adapter and Webbrowser				
	Relay contacts (optionally) Eight Signals via additional expansion card				
Environment	Temperature 0-40°C (Battery 0 - +25°C)				
	Humidity 20-80% non condensing				
	Audible noise (1m distance) < 50dBA				
Weight	Without batteries	90kgs	100kgs	100kgs	141kgs
	With batteries	250kgs	260kgs	260kgs	on request
Dimensions	HxWxD in mm 1200 x 450 x 650				
Safety	EN 50091-2, CE				
Enclosure	IP 20				
Colour	RAL 7035				

Pegasus 60-160kVA

60, 80, 100, 125, 160kVA 3/3 phase



Online double-conversion 60, 80, 100, 125, 160kVA

The PEGASUS is a online double-conversion UPS system with 3-phase output. It can be configured parallel-redundant and increases the availability of the power source.

The usage of IGBT rectifiers reduces the distortion of dependent mains. The current drain is almost ideal sinus and the power factor was increased in comparison to traditional thyristor design.

The output isolation transformer of the PEGASUS UPS provides the galvanic isolation between consumer load and DC intermediate circuit and battery.

The electronic components are up to highest standards as known from military requirements. So you find an UPS system with enhanced reliability, availability and safety.

- UPS classification VFI-SS111 in accordance with IEC 62040-3
- Online double-conversion
- IGBT rectifier
- Output isolation transformer
- Power factor >0,99
- Output sine wave
- Digital control
- Comfortable LCD display
- Compact design
- RS-232 (equipped as standard)
- Additional slot for optional relaycard, RS485- or SNMP-adapter
- 24 months' warranty

- Optionally incl. BACS battery management
- Optionally up to 6 devices parallel
- Optionally external battery extension

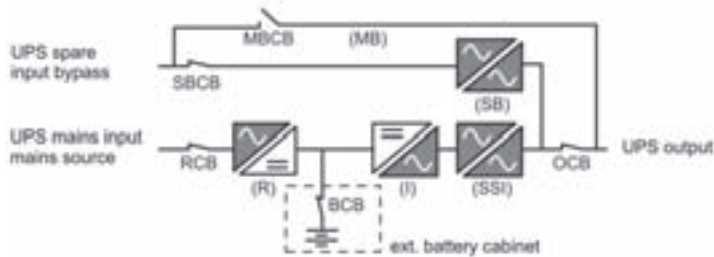

block diagram

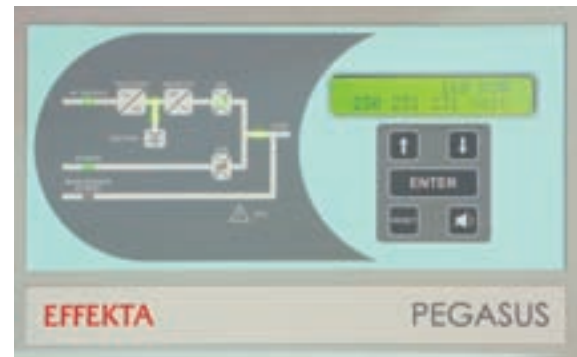

control panel

Specifications

Model	PEGASUS 60kVA	PEGASUS 80kVA	PEGASUS 100kVA	PEGASUS 125kVA	PEGASUS 160kVA	
Power	60kVA / 48kW	80kVA / 64kW	100kVA / 80kW	125kVA / 100kW	160kVA / 128kW	
Efficiency (AC-AC) - % (ECO mode)	>98					
Efficiency (AC-AC) - % (Online mode)	>93					
Input	Voltage nominal					
	Voltage tolerance					
	Frequency					
	Power factor (@ 400V)					
Output	Voltage					
	Frequency					
	Waveform					
	Output current nominal @ CosPhi 0.8/1.0					
	Short-circuit current					
	Distortion					
	Crest factor					
Batteries	Type					
	Capacity					
	Cells					
	Autonomy					
	Nominal voltage					
	Minimal discharging voltage					
	Charging voltage					
	Recharging time					
	Transfer time	AC-DC to bypass				
	Display	LCD				
LED						
Acoustic alarm	Resettable					
Interface	RS-232 Interface					
	SNMP					
	Relay contacts					
Environment	Temperature					
	Humidity					
	Audible noise (@ 1m distance)					
Weight	Without batteries					
Dimensions	HxWxD in mm					
Safety	EN 50091-2, CE					
Enclosure	IP 20					
Color	RAL 7035					

Pegasus 200-300kVA

200-300 kVA 3/3-phase



Online double-conversion 200, 250, 300kVA

The PEGASUS is a online double-conversion UPS system with 3-phase output. It can be configured parallel-redundant and increases the availability of the power source.

The electronic components are up to highest standards as known from military requirements. So you find an UPS system with enhanced reliability, availability and safety.

The usage of IGBT rectifiers reduces the distortion of depended mains. The current drain is almost ideal sinus and the power factor was increased in comparance to traditional thyristor design.

The output isolation transformer of the PEGASUS UPS provides the galvanic isolation between consumer load and DC intermediate circuit and battery.

- UPS classification VFI-SS111 in accordance with IEC 62040-3
- Online double-conversion
- IGBT rectifier
- output isolation transformer
- Input power factor >0.96
- Output sine wave
- Digital control
- Comfortable LCD display
- Compact design
- RS-232 (equipped as standard)
- Additional slot for optional relaycard, RS485- or SNMP-adapter
- 24 months' warranty

- Optionally incl. BACS battery management
- Optionally up to 6 devices parallel
- Optionally external battery extension

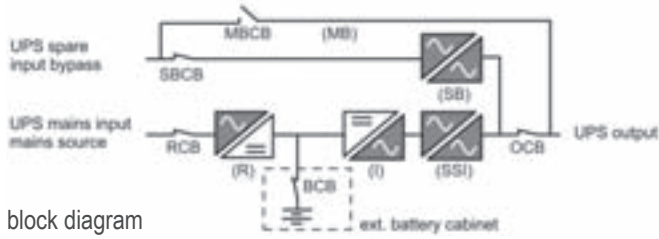

block diagram

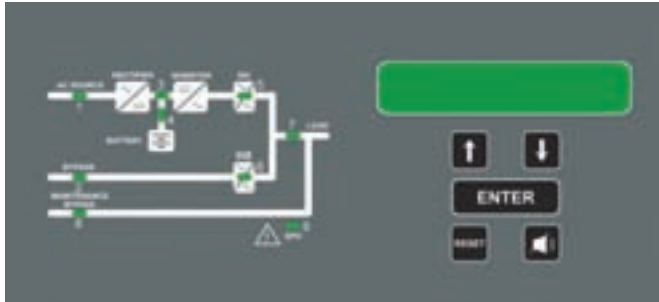

control panel



UPS electronics

Specifications

Model		PEGASUS 200kVA	PEGASUS 250kVA	PEGASUS 300kVA
Power		200kVA / 160kW	250kVA / 200kW	300kVA / 240kW
Efficiency (AC-AC) - % (ECO mode)		>97	>97	>97
Efficiency (AC-AC) - % (Online mode)		>93	>93	>93
Input	Voltage nominal	3-ph. 400VAC		
	Voltage tolerance	380-400-415VAC +10% / -20%		
	Frequency	50Hz - 60Hz +/- 5Hz		
	Power factor (@ 400V)	>0.96		
Output	Voltage	380-415VAC +/- 1% einstellbar		
	Frequency	50Hz or 60Hz +/- 0.001Hz (battery mode) +/- 2Hz synchronised (line mode)		
	waveform	Sinus		
	Output current nominal @ CosPhi 0.8/1.0	290/230A	360/290A	430/360A
	Short-circuit current	462A	520A	578A
	Distortion	<2% (linear load), <5% (nonlinear load), in accordance to IEC 62040-3		
	Crest factor	3:1		
Batteries	Type	Maintenance free lead acid batteries		
	Capacity	On request	On request	On request
	Cells	300	300	300
	Autonomy	On request	On request	On request
	Nominal voltage	600VDC bei 25°C		
	Minimal discharging voltage	496VDC		
	Charging voltage	On request	On request	On request
	Recharging time	7-8h 90% capacity		
Transfer time	AC-DC to bypass			
Display	LCD	Alphanumeric backlit display		
	LED	Diagram with LEDs		
Acoustic alarm	Resetable			
Interface	RS-232 Interface	Yes		
	SNMP (Option)	Yes		
	Relay contacts	Powermanagement via optional SNMP adapter and webbrowser		
Environmentz	Temperature	Via additional expansion card		
	Humidity	0-40°C (batteries 0- +25°C)		
	Audible noise (@ 1m distance)	<95% noncondensing		
		< 62dBA		
Weight	Without batteries	870kgs	1020kgs	1200kgs
Dimensions	HxWxD in mm	1900 x 1200 x 860	1900 x 1200 x 860	1900 x 1200 x 860
Safety		EN 50091-2, CE		
Enclosure		IP 20		
Colour		RAL 7035		

MHD Modular



Online double-conversion 4-24kVA

MHD Modular is a scalable single phase or three-phase double-conversion UPS and can be configured to a capacity of 4kVA, 8kVA, 12kVA, 16kVA, 20kVA, 24kVA with maximum 6 modules. It can be configured to parallel redundancy which provides the maximum reliability. And delivers power output per modules from 4kVA to 24 kVA.

The MHD Modular is scalable in the capacity between 4-24kVA as well as scalable in autonomy time with additional external battery cabinetts, or it can be configured for a N+X parallel redundancy as well..

Each UPS system includes maximum six UPS modules that each module is operating independetly. If any one UPS module fails, the load is instantaneously redistributed among the remaining modules and the defective UPS module is automatically taken off-line from the system. Maintenance personnel can easily change the defective module during normal operation without disturbing the reliability.

- UPS-classification VFI-SS-111 (IEC 62040-3)
- Online double-conversion
- Modular design
- Scalable capacity in 4kVA steps up to 24kVA
- 1- or 3-phase input
- Hot swappable modules
- Sinewave output
- Digital signalprocessor
- Clearly arranged LCD display
- Modular battery extension
- Optionally incl. BACS battery management
- Compact design
- Little weight
- RS232, RS485 and expansion slots for different communication ports (SNMP, Relais)
- 24 months' warranty



Casing variation with additional space for isolation transformer or other

The 4kVA-modules of EFFEKTA® MHD Modular provide advanced UPS technology with high operating efficiency. The System absolutely prevents power failures, power sags, surges, brownouts, line noise, spikes, frequency variations switching transients and harmonic distortion.

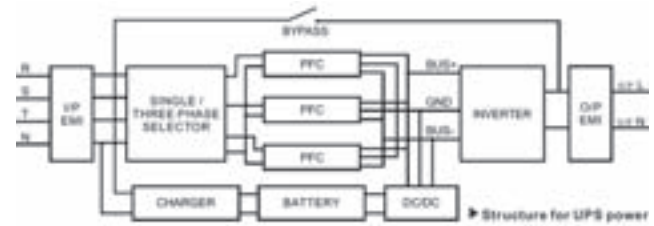

With its fast DSP-controller (Digital Signal Processing) it offers a highend sinewave-quality and high performance in controlling input & output.

The display of MHD Modular shows all important UPS informations in a userfriendly way. The backlight improves the readability. All important messages concerning the configuration and diagnosis as well as controls and management of the UPS can be seen at a glance.



You can watch all data like input and output voltage, frequency, connection data, position and and actual state of the modules. The facility of inspection is provided by additional LEDs for informations about most impoertant state of operation like „normal“, „on battery“, „bypass“ and „fault“.



Also the MHD Modular provides communication ports for remote monitoring via EDP. Standard are a RS232 and RS485 port at ther rear of the UPS. Additionally the intelligent slot provides more options for EDP or other monitoring functions for your UPS management. Amongst others SNMP-/WEB adapters or relais cards could be used.

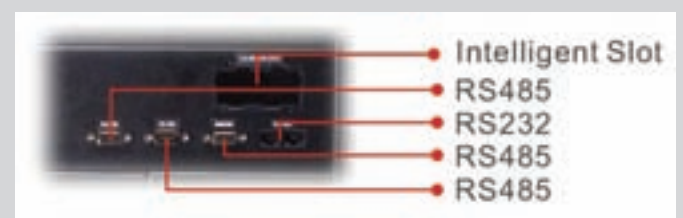

MHD Modular

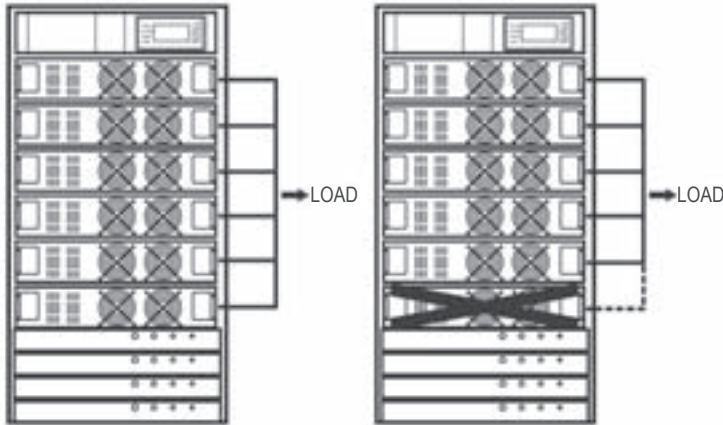

The MHD Modular is a scalable online double-conversion UPS and with up to 6 modules it can be configured to 4kVA, 8kVA, 12kVA, 16kVA, 20kVA and 24kVA.

One of the most important advantages of the modular and redundant design is the improved safety and reliability. If the MHD Modular is configured to N+X parallel-redundancy, the load is instantaneously redistributed among the remaining modules. Because each module is a separately operating device, there is no central control system that could be damaged, so this also increases the safety.

The MHD Modular has got hardwired outputs with one phase and can be used with one or three phase inputs alternatively. In case of operating with three phases, each of them is monitored by the UPS.

Additional modules can be installed to the MHD Modular during normal operation without much time and effort. This hot swappable method provides subsequent extension of the UPS system without any disturbance of normal operation of the users, so this system provides saving of costs. Also the possibility to change defective modules during normal operation without any disturbance of the users leads to more saving of costs.

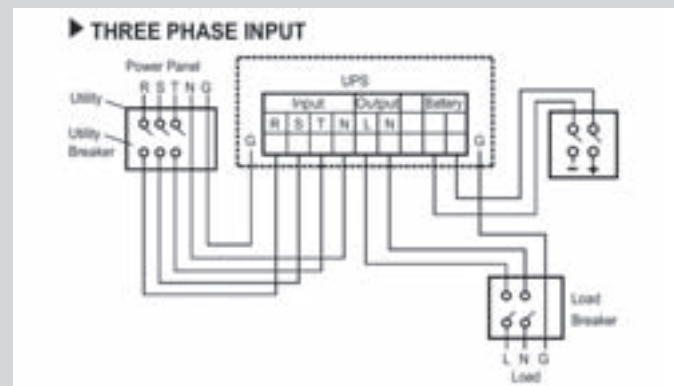
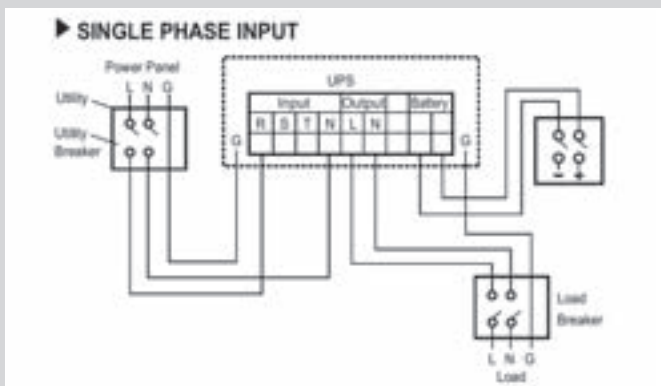
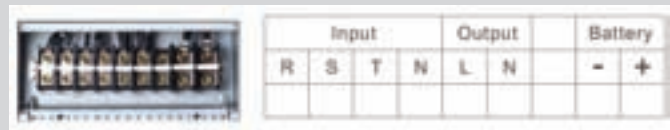

Specifications

Number of modules-capacity	1 Module	2 Modules	3 Modules	4 Modules	5 Modules	6 Modules
4kVA	N	N+1 (4kVA)	N+2 (8kVA)	N+3 (12kVA)	N+4 (16kVA)	N+5 (20kVA)
8kVA		N	N+1 (4kVA)	N+2 (8kVA)	N+3 (12kVA)	N+4 (16kVA)
12kVA			N	N+1 (4kVA)	N+2 (8kVA)	N+3 (12kVA)
16kVA				N	N+1 (4kVA)	N+2 (8kVA)
20kVA					N	N+1 (4kVA)
24kVA						N

Model		MHD Modular		
Capacity		4~24kVA		
Input	Singel / three phase		Single phase	
	Wiring		1Φ2W + G	
	Voltage	70% load	160~300VAC	
		50-70% load	140~300VAC	
		50% load	118~300VAC	
	Input frequency		50/60 (1±8%) Hz	
Power factor		0,98		
Bypass		80~264VAC	140~457VAC	
Output	Phase		Single phase	
	Wiring		1Φ2W + G	
	Voltage		230 (±2%) VAC	
	Power factor		0,7	
	Output frequency		Same as input frequency	
	Overload		50/60 (1±0,5%) Hz (backup mode) 110-130%, after 30 seconds transfer to bypass >130%, after 2 seconds transfer to bypass	
	Capacity / module		4kVA	
Output capacity		4kVA x number of modules		
External batteries		120VDC (10 batteries in each cabinet)		
Connect to generator		Yes		
Communication / interface		RS232, RS485, intelligent slot		
Weight	Module	15kg		
	Cabinet	75kg		
Dimensions of modules HxWxD in mm		88x430x530		
Dimensions of cabinet HxWxD in mm		965x442x700		

Battery capacity / autonomy time

Capacity VA	Capacity watt	Number of modules	Autonomy minutes	Battery configuration
4000	2800	1	30	120V-28Ah
4000	2800	1	40	120V-45Ah
4000	2800	1	60	2x120V-28Ah
4000	2800	1	90	120V-65Ah
8000	5600	2	10	120V-28Ah
8000	5600	2	25	120V-45Ah
8000	5600	2	30	2x120V-28Ah
8000	5600	2	45	3x120V-28Ah

Capacity VA	Capacity watt	Number of modules	Autonomy minutes	Battery configuration
12000	8400	3	15	2x120V-28Ah
12000	8400	3	20	120V-65Ah
12000	8400	3	30	3x120V-28Ah
16000	11200	4	10	2x120V-28Ah
16000	11200	4	15	120V-65Ah
16000	11200	4	20	3x120V-28Ah
20000	14000	5	15	3x120V-28Ah
20000	14000	5	25	2x120V-65Ah
24000	16800	6	10	3x120V-28Ah
24000	16800	6	20	2x120V-65Ah

MHD Modular P3

NEU / NEW



Online double-conversion
15, 30, 45, 60, 75, 90, 105, 120kVA
with 3-phase input and output, n+X redundancy

EFFEKTA®s' MHD Modular P3 covers the area of redundant systems with 3-phase connection from up to 120kVA.

It can accommodate up to 8 15kVA UPS-modules, which could be exchanged or added during a continuously operation („Hot-Swappable“). In case of failure or removal of a module, the load redistribute automatically and without interruption to the remaining modules.

All settings, such as module number and parallel redundancy can be performed comfortably over the control panel with LCD display.

Features

- UPS-classification VFI-SS-111 in accordance with IEC 62040-3
- Online double-conversion with sinus output
- Modular design for up to 8 UPS-modules
- Up to 99,99% availability through n+X redundancy
- All modules „Hot-Swappable“
- Allmost sine-wave current consumption and high efficiency
- Suitable for generator operation
- Clear front control panel incl. multilingual LCD-Display
- Interface for EPO remote control
- Expandable autonomy time
- 24 months' warranty

Options:

- Front operable Power-Distribution-Panel
- External battery cabinet
- Output isolating transformer
- Slot for optional communication adapter

AC large modular UPS 4-120kVA



UPS and battery status, parameters and warnings are shown on the control panel with LCD-display. After start-up of the UPS, all operations could be done over the control panel.

With N+S-redundancy, the MHD Modular P3 offers the most reliable power supply configuration.

N = Minimum number of required modules for the total load on the UPS.

X = Number of redundant modules of the UPS.

Specifications

Power system		15-120kVA (maximum 8 modules in parallel configuration)
Power modul		15kVA / 12kW
Efficiency (AC-AC) - % (Online-mode)		> 90%
Input	Voltage nominal	400VAC 3 phase + neutral conductor + ground / wye connection
	Voltage tolerance	204 ~ 520VAC 100% linear o. non linear load
	Frequency	50Hz / 60Hz adjustable
	Power Factor	0.99
Output	Voltage	380 / 400VAC
	Frequency	50/60Hz ± 0.05Hz (battery mode) ± 1Hz synchronised (line mode)
	Voltage form	Sinus wave
	Distortion	< 3% (linear load), 5% (non linear load), in accordance with IEC 62040-3
	Crest factor	3:1
Batteries	Type	Maintenance free sealed lead-acid battery
	Capacity	Configuration dependent
	Autonomy	10 minutes by nominal load / expandable
	Voltage nominal	480VDC
	Min. discharge voltage	400VDC
	Charging voltage	548VDC ± 1%
	Charging time	7-8h at 90% of total capacity after complete discharge
Transfertime	AC-DC to bypass	< 1ms
Display	LCD	Alphanumeric display
	LED	Normal operation / battery / bypass / failure
Acoustic alarm	Restable	Yes
Interface	RS-232 Interface	RS232, RS485, IntelligentSlot
	SNMP (optional)	Powermanagement via optional SNMP-Adapter and Webbrowser
	Relay contacts (optional)	4 signals via additional expansion card
Environment	Temperature	0-40°C (storage -25°C - 55°C)
	Humidity	20-90% non condensing
	Audible noise	< 62dBA
Weight	Cabinet	250kg
	Modul	35kg
Dimensons	Cabinet HxWxD in mm	2000 x 600 x 1000
	Modul HxWxD in mm	131 x 700 x 440
Enclosure		CE EMI: IEC/EN 62040-2 / EMS: IEC/EN 61000-4-2/3/4/5/6/8 / IEC/EN 61000-2-2
Safety		IP 20
Colour		black

Software

for all EFFEKTA® AC UPSs (400VA-300kVA)



The UPS management software solution PowerShut Plus runs as a client/server application for heterogeneous networks or local computers. It works on Windows 95/98/2000/NT/XP/Vista (Business and higher), Novell, Linux and all current Unix derivatives. It also includes an SNMP agent for Windows NT and Novell. All Servers on the network can be shut down via RCCMD (Multiserver-Shutdown). The software provides all important UPS information such as battery level, temperature, condition of line-voltage and others in clear graphical displays. Disruptions can be reported by e-mail, mobile phone or fax.

- Available for Windows 9x, NT, 2K, 2003 Server, XP, Vista (Business and higher), Netware, Macintosh, UNIX and VMS
- UPS monitoring via floating contacts or serial interface
- Local or network shutdown on up to several hundred computers
- Integrated SNMP subagent (RFC 1628)
- Graphical interface with all UPS information
- Graphical interface on UNIX, MAC, VMS (JAVAMON)
- Event-based dispatch of network messages
- Event-based dispatch of e-mails and SMS
- Logging of all UPS status information and measurements in MS-Excel file
- Schedulers for time-controlled execution of reboot, shutdown etc.

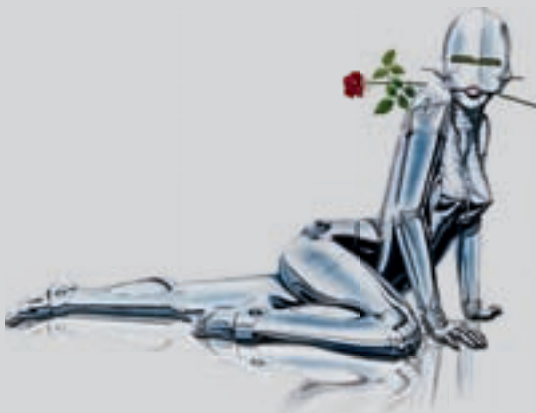

SNMP

for all EFFEKTA® AC UPSs (400VA-300kVA)



CS 121 SNMP adapter

The CS121 is equipped with a 32-bit processor, 8 MB RAM, 4 MB Flash, 2 serial interfaces and a 10/100MBIT network connection.

COM1 is provided for communication with the UPS, COM2 may be used for configuring the adapter, connection to a modem or to forwarding UPS data to other computers.

Other features in the area of UPS visualisation and the remote-controlled network shutdown option (RCCMD) make the CS121 easy to operate and increase its range of application.

Optionally the CS121 "Budget" (right hand picture) is available for reasonable network solutions. This version of the adapter is for the limited purpose of network communication, so it is not equipped with the additional interfaces of the "Professional" version (picture at the top of the page).

- Powerful 32-bit RISC processor, 8MB RAM, 4MB Flash
- Supported protocols: SNMP, HTTP, Telnet, UPSMON, PPP/ SLIP, SMTP and FTP, Modbus
- 10/100 Mbit Ethernet connection
- 2 serial RS-232 interfaces (RS-422/ 485 optional)
- Modem support for UPS dialer and internet connection
- Integrated WEB server
- Visualisation via UPSMON, JAVAMON, UNMS, NMS, WEB browser or TELNET
- Support UPS standard MIB RFC1628





Configuration and monitoring via web browser

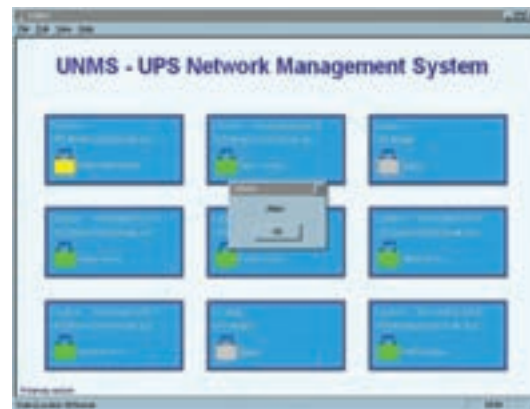

UNMS (9 UPSs)

UPSMAN module

- UPS monitoring via floating contacts or serial interface
- Local or network shutdown
- Event-based dispatch of network messages
- Event-based dispatch of e-mails and SMS
- Schedulers for time-controlled execution of reboot, shutdown etc.
- Password protection for all UPS remote-functions
- Configuration via common web browsers
- Monitoring via UPSMON possible

UNMS UPS monitoring panel (freeware)

Available for Windows 95/ 98/ ME/ NT/ 2000 / XP / Vista (Business and higher)

- Clear representation of all network UPS
- Up to 9 UPS in network can be monitored (freeware version)
- Simple configuration
- Number of connections adjustable
- Acoustic alert
- Expandable on request
- SNMP adapter support
- Up to 1500 nodes optional

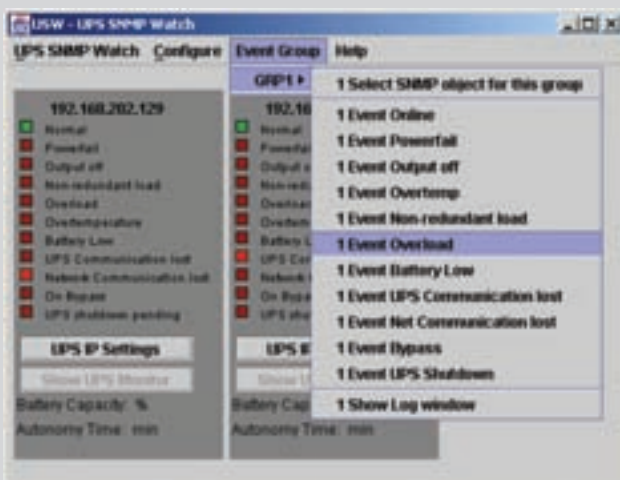

USW ("UPS SNMP Watch", left hand image)

- Monitoring of parallel and single UPSs
- Clear representation of all UPS status information
- User-defined configuration of all events
- Sequential network shutdown of computers in homogeneous and heterogeneous networks
- Available for UNIX and Windows NT/ 2000 / XP / Vista (Business and higher)
- UPS control via SNMP adapter and SNMP software agent (UPSMAN)
- Further graphical interfaces started via mouse-click (UPSMON, JAVAMON)
- Java-based program

External bypass

An external bypass can be used to guarantee optimum availability of the EFFEKTA® UPS systems, particularly for critical applications. During UPS maintenance, the bypass bridge the UPS and provides the load with uninterrupted power after a manual changeover.



Type	Z00/Byp016A-000
Adaptable up to (UPS power in kVA)	3kVA
Socket	Single-phase hardwired
Mounting/construction	Wall-mounting



Type	Z00/Byp016A-A02
Adaptable up to (UPS power in kVA)	3kVA
Socket	Single-phase pluggable
Mounting/construction	19" rack, 2U



Type	ZRO/Bypk40A-000
Adaptable up to (UPS power in kVA)	6kVA
Socket	Single-phase hardwired
Mounting/construction	19" rack, 2U



Type	Z00/Byp063A-000
Adaptable up to (UPS power in kVA)	30kVA
Socket	Three-phase hardwired Optionally one-phase hardwired
Mounting/construction	Wall-mounting



Type	Z00/Byp100A-000
Adaptable up to (UPS power in kVA)	40kVA
Socket	Three-phase hardwired
Mounting/construction	Wall-mounting

Further models on request.

Battery cabinets



B10

Battery cabinet for UPSs in office premises

Steel cabinet with synthetic front (IP 20)

Article	Dimensions (H x W x D in mm)	Adapted battery type	Max. number of batteries
B10/...	207x140x437	BFR/BT12-7	8
B10/...	207x140x437	BFR/BT12-9.5	8

B28

Battery cabinet for small and medium UPS types.

Lacquered steel construction (black / IP20) on casters.

Optionally with BACS incl. LCD Display.

Article	Dimensions (H x W x D in mm)	Adapted battery type	Max. number of batteries
B28	445 x 285 x 520	BT 12-28 (12V / 28Ah)	8
B28 BACS	445 x 285 x 520	BT 12-28 (12V / 28Ah)	8



B30

Battery cabinet for large UPSs or high autonomy times

Powder-coated steel construction (IP 20)

Article	Dimensions (H x W x D in mm)	Adapted battery type	Max. number of batteries
B30/S600-3	1220x580x950	BZR/BTL12-33	32
B30/S600-4	1220x580x950	BZR/BTL12-45	32
B30/S800-3	1220x770x950	BZR/BTL12-55	32
B30/S800-4	1220x770x950	BZR/BTL12-65	32
B30/S800-4	1220x770x950	BZR/BTL12-80	32

B40

Battery cabinet for large UPSs or high autonomy times

Powder-coated steel construction (IP 20)

Article	Dimensions (H x W x D in mm)	Adapted battery type	Max. number of batteries
B40/...	on request	BZR/BTL12-100	on request
B40/...	on request	BZR/BTL12-120	on request
B40/...	on request	BZR/BTL12-150	on request
B40/...	on request	BZR/BTL12-200	on request



BT batteries



BT 12-18



BT 12-28

Our long-standing experience with emergency power systems and uninterruptible power supply units is our guarantee for the highest quality and reliability of EFFEKTA® batteries.

BT batteries are ideally suited for use in:

- Uninterruptible power supplies (UPSs)
- Telecommunications systems
- Fire alarm and safety systems
- Medical equipment
- Photovoltaic applications

Advantage of BT batteries:

- Fully maintenance-free
- High recombination in cycle activity
- Valve-regulated plastic container as overload protection
- Excellent high-current capability
- Classified as non-dangerous in accordance with IATA
- Cycle-resistant (more than 400 recharging/discharging cycles up to 50% DOD)
- Robust construction
- Location-independent



BT 12-0.8



BT 12-5



BT 12-7
VdS certified

Specifications

Type	Voltage in (V)	Capacity in Ah (C20)	L (mm)	W (mm)	H (mm)	H (mm) max.	Weight in kg	Terminal standard / optional
12V types								
BT 12-1,2	12	1,2	97	43	52	58	0.6	F1
BT 12-2,3	12	2,3	178	34,5	60,5	66,5	0.97	F1
BT 12-2,8	12	2,8	104,5	47,5	69,5	69,5	1	F2/F1
BT 12-2,9	12	2,9	79,5	56	99	105	1.1	F1
BT 12-3,2	12	3,2	134,5	67	59,5	65,5	1.3	F1
BT 12-5	12	5	90	70	101	107	1.7	F1/F2
BT 12-7E	12	7	151	65	95	101	2.15	F2
BT 12-7 (VdS)	12	7	151	65	95	101	2.26	F2/S-type: F1
BT 12-9	12	9	151	65	95	101	2.4	F2
BT 12-9,5	12	9,5	151	65	95	101	2.63	F2
BT 12-12	12	12	151	98	95	101	3.6	F2
BT 12-18	12	18	181	77	167	167	5	F3
BT 12-18i	12	18	181	77	167	167	5	F13
BT 12-20	12	20	181	77	167	167	5.9	F3/F13
BT 12-28	12	28	166	175	125	125	8.6	F13
BT 12-28S	12	28	166	126	174	174	8.6	F11
6V types								
BT 6-3,2	6	3,2	134	34	60,5	66,5	0.65	F1
BT 6-12	6	12	151	50	95	100	1.8	F1/F2

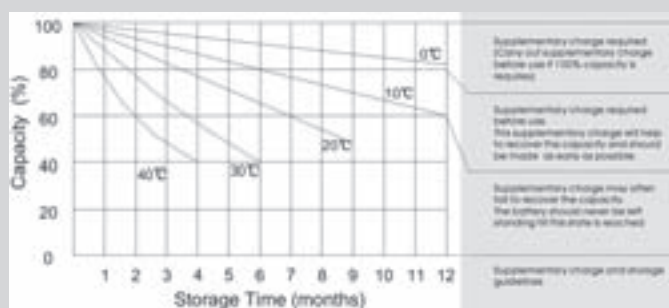
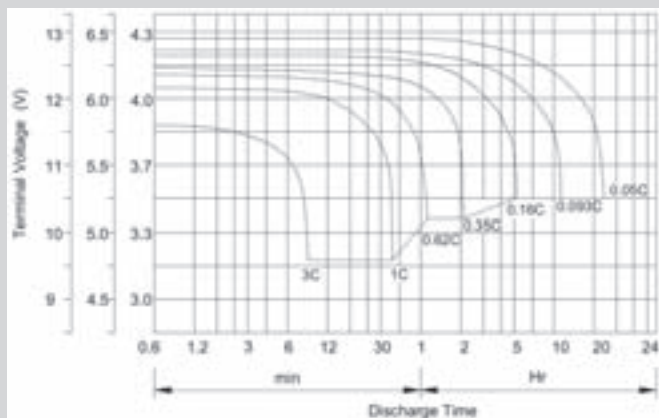
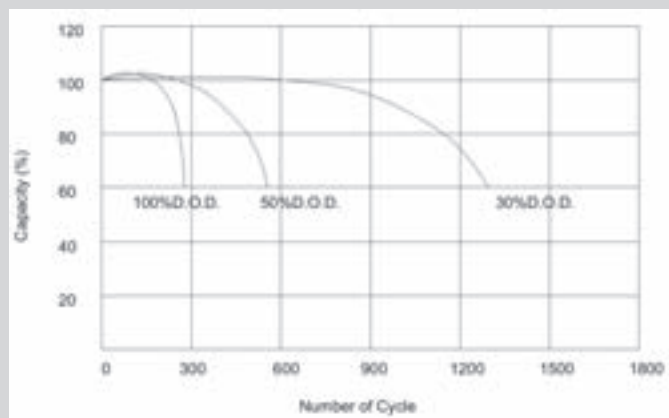
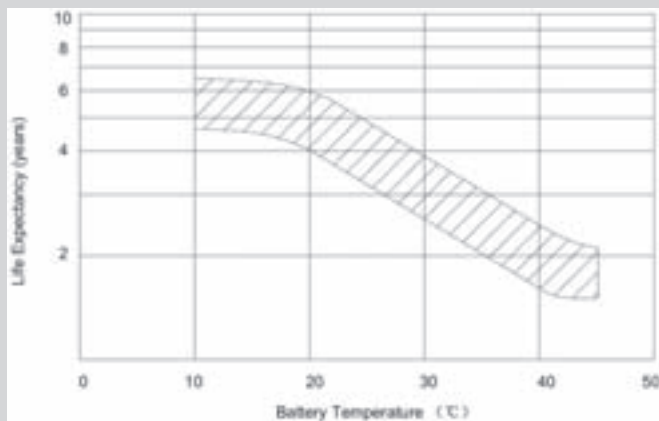
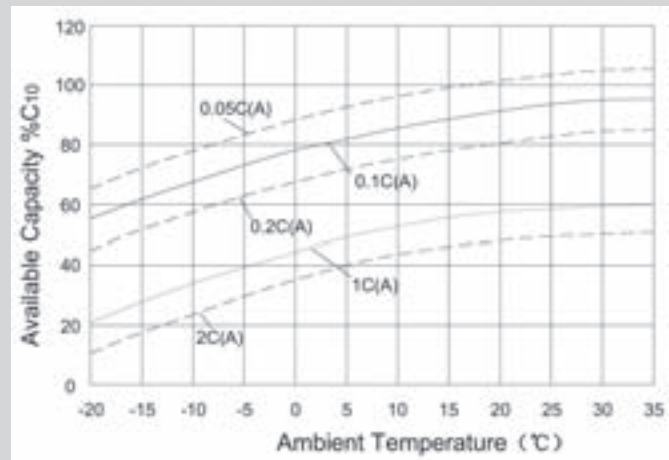
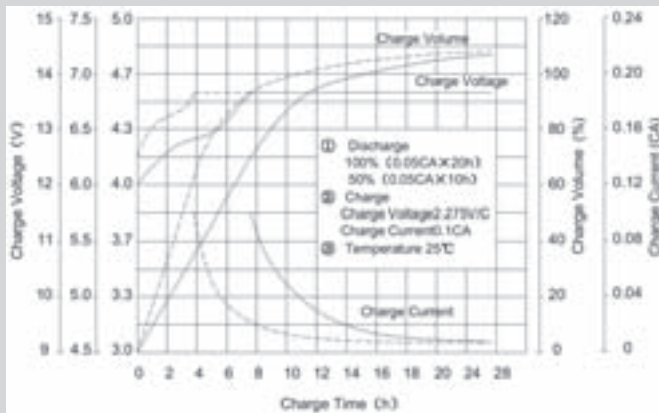

BTL batteries



BTL 12-100



BTL 12-65

Our long-standing experience with emergency power systems and uninterruptible power supply units is our guarantee for the highest quality and reliability of EFFEKTA® batteries.

BTL batteries are ideally suited to use in:

- Uninterruptible power supplies (UPSs)
- Telecommunications systems
- Fire alarm and safety systems
- Medical equipment
- Photovoltaic application
- Emergency lighting systems

Advantage of BTL batteries:

- Absolutely maintenance-free
- High recombination in cycle activity
- Valve-regulated plastic container as overload protection
- Excellent high-current capability
- Classified as non-dangerous in accordance with IATA
- Long service life of approx. 10 years
- Cycle-resistant (more than 500 recharging/discharging cycles up to 50% DOD)
- Robust construction
- Location-independent



BTL 12-45



BTL 12-55



BTL 12-33

Specifications

Type	Voltage (V)	Capacity in Ah (C20)	L (mm)	W (mm)	H (mm)	H (mm) max.	Weight (kg)	Terminal
12V types								
BTL 12-33	12	33	195	130	159	180	10.2	F11
BTL 12-45	12	45	198	166	170	170	13.2	F11
BTL 12-55	12	55	229	138	210	235	18	F11
BTL 12-60	12	60	260	169	210	235	20.5	F11
BTL 12-65	12	65	350	167	180	183	21	F11
BTL 12-75	12	75	260	169	210	235	23.5	F11
BTL 12-80	12	80	350	167	180	183	24	F11
BTL 12-90	12	90	306	169	210	217	28.5	F12/F5
BTL 12-100	12	100	320	172	220	227	30	F12/F5
BTL 12-120	12	120	407	177	227	227	35	F12/F5
BTL 12-120S	12	120	330	171	220	227	32	F12/F5
BTL 12-150	12	150	483	170	240	240	44.5	F12/F5
BTL 12-200	12	200	522	240	218	240	60	F12/F5
6V types								
BTL 6-100	6	100	194	170	205	322	16.5	On request

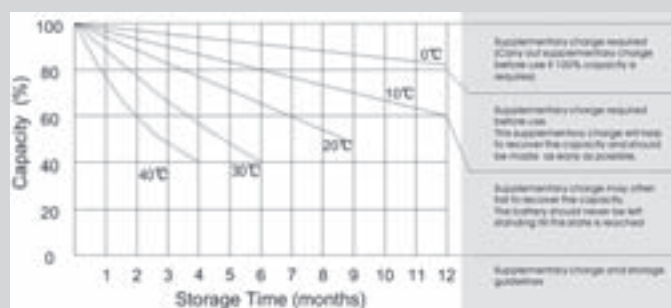
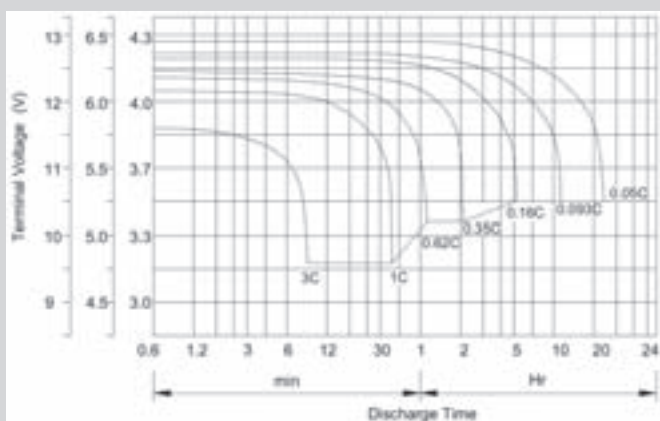
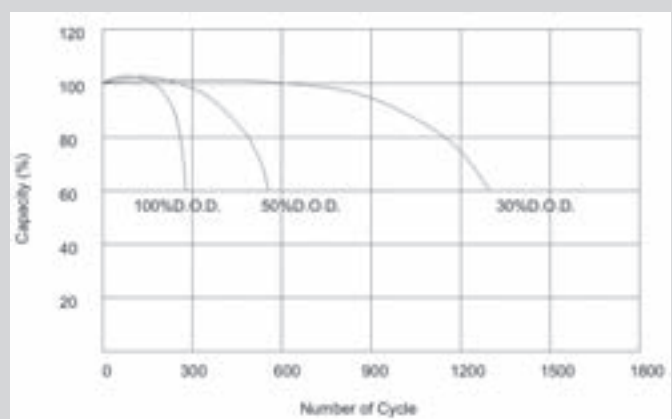
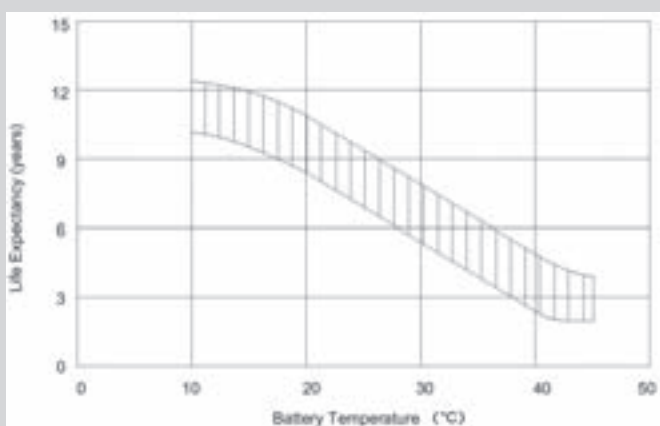
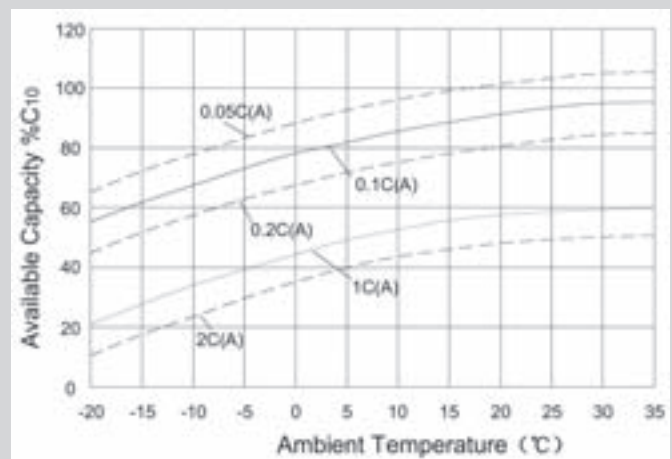
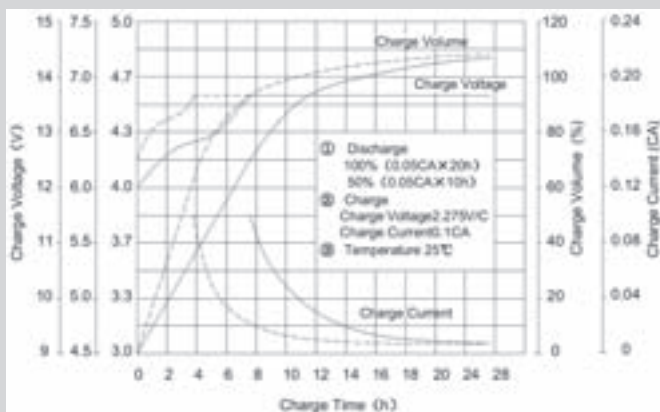

Front terminal batteries

BTL front terminal batteries from EFFEKTA® have the same electrical construction as batteries of the BTL types. However the special dimensions of the batteries mean that they are compact and easy to maintain especially in 19" rack cabinets.



BFR/BTL12-55F
(left-hand image: terminals)



BFR/BTL12-150F
(right-hand image: terminals)



BFR/BTL12-105F
(right-hand image: terminals)

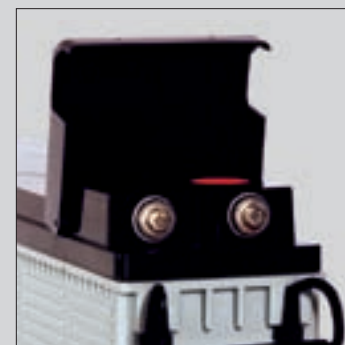

BTL Series type	Voltage in (V)	Capacity in Ah (C20)	L (mm)	W (mm)	H (mm)	H (mm) max.	Weight in kg	Terminal
BTL 12-55F	12	55	277	106	222	222	18	F12
BTL 12-90F	12	90	563	114	188	188	26.5	F12
BTL 12-105F	12	105	502	111	236	236	32.5	F12
BTL 12-110F	12	110	394	110	286	286	33	F12
BTL 12-150F	12	150	552	110	288	288	45	F12

Terminals

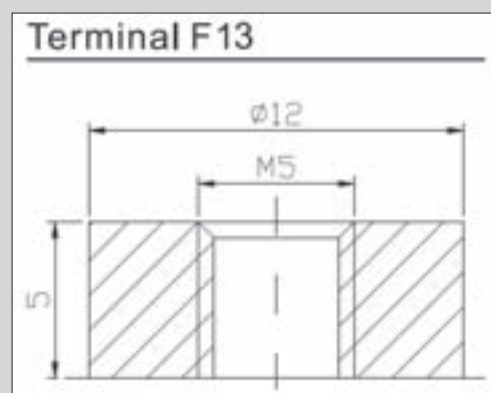
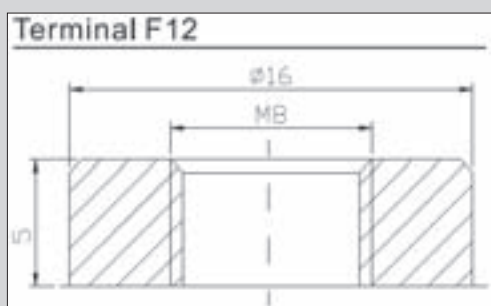
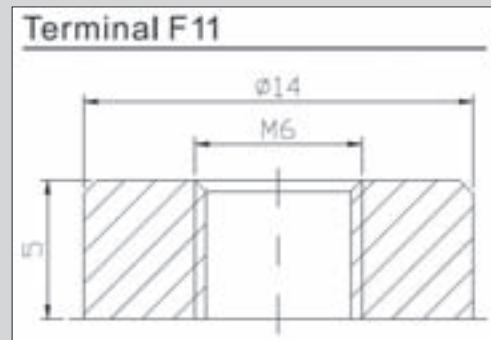
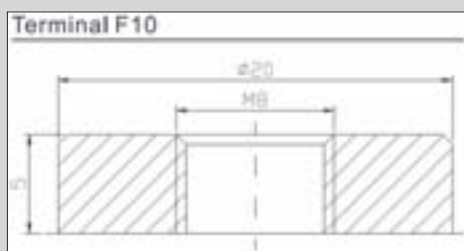
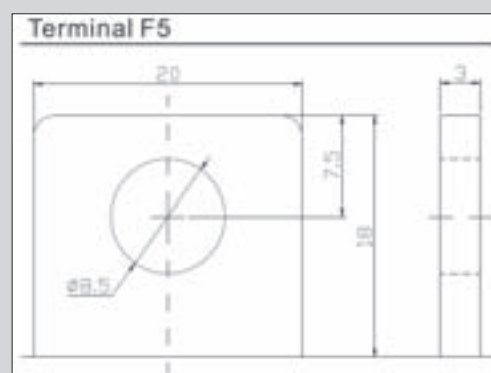
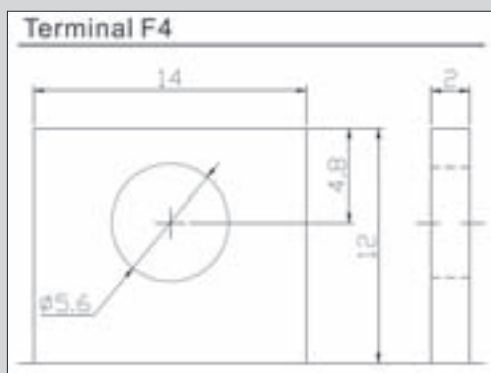
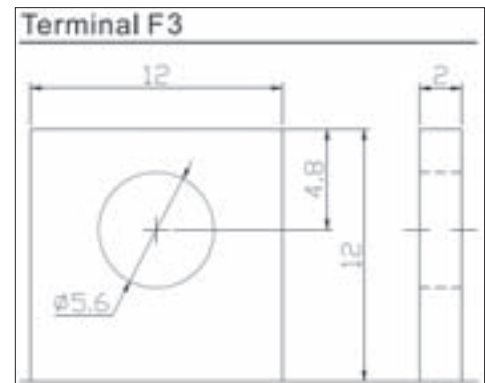
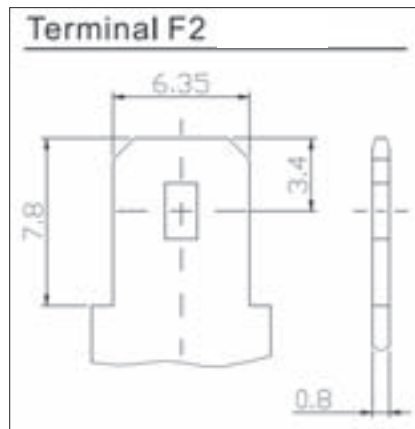
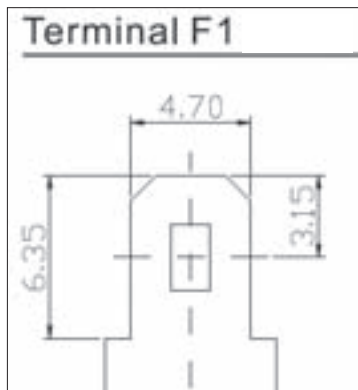

More information on request.

BACS

BACS, the Battery Analysis & Care System, represents a groundbreaking innovation in the field of battery secured power supplies. This patent-pending technology sets completely new standards in terms of true battery management. BACS guarantees optimum safety and capacity of the battery pack throughout its entire life cycle, thus safeguarding the functionality of your power supplies.

BACS is available as build-in-version as well as external version for many EFFEKTA®-UPSs. It is also available on demand for different battery-systems.



General functions of BACS:

- Automatic adjustment of the battery pack to parent systems (control circuits enable automatic harmonisation with the charger)
- Uniform battery statuses are guaranteed via a controlled equalizing process
- Internal resistance, temperature and voltage measurements enable battery status monitoring and automatic compensation of key parameters
- The system is equipped with a status display with alarm output
- Communication via RS232, SNMP or voltage-free contacts

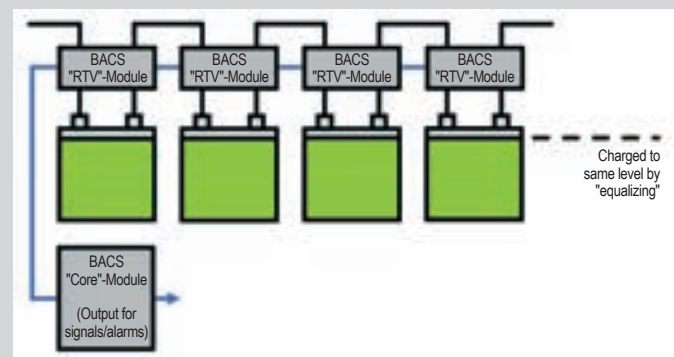

BACS can find out each damaged or weak battery before the whole system gets critical



Integration of BACS technology benefits a complete system (battery pack) in the following ways:

- Increase in useful life of the batteries and consequently also the entire battery pack.
- Guarantees maximum possible system capacity at all times (increase of up to 20%).
- Warnings output in the case of weak or defective systems, in particular display of the defective battery block. Important especially in safety-critical areas such as UPS equipment.
- Alarm if maximum ratings are exceeded (e.g. excessive battery voltage or temperature).
- Existing UPS equipment can be upgraded at any time
- Individual battery blocks can be exchanged (traditional battery management requires all batteries to be exchanged).

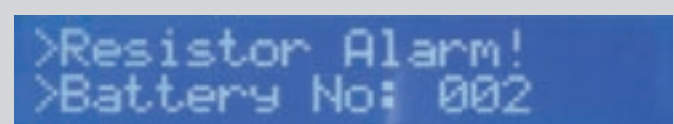
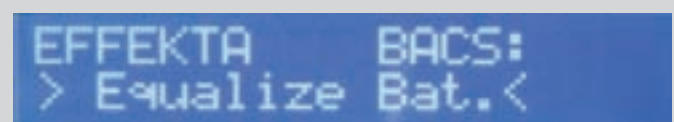

Top image: MHD-display with BACS-messages

BACS

How BACS works and its benefits in comparison to conventional battery-management-systems:

Traditionally, batteries in all common UPS systems have been connected and charged in series. The voltage present at the batteries is monitored. This is normally approx. 12-13V or a multiple thereof in accordance with the battery voltage. In this way, it is possible to measure whether the necessary voltage to supply the required battery capacity is available. EFFEKTA®'s BACS is working more accurately:

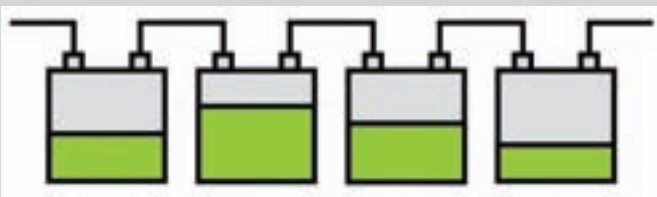

Fig. 1: In series connected and charged batteries have different capacity because of different conditions. As a result of natural ageing, these batteries already have different charge statuses after only a short period of use due to internal chemical processes.



Fig. 2: Standard charging of the batteries using traditional methods causes overcharging or deep discharging and damage to individual batteries, which in turn compromises the reliability of the entire system.

The BACS benefits:

1. Each battery is individually monitored via a dedicated processor-controlled "RTV" module. This also enables defective batteries on a system to be identified.

This eliminates one important weak spot of conventional systems: Even defective or discharged batteries can supply the required 12-13V for a short period, which often causes the incorrect assumption in battery management terms that the battery status is OK. This leads to an excessively rapid discharge in the case of a power failure. Not so with BACS because weak or defective batteries are reported on time.

2. The user is informed of defective or weak batteries BEFORE any potential damage occurs.

In conventional systems the capacity of the battery/batteries is actually depleted, although the display (LED chain, LCD display or software) states otherwise. (s. item 1.) The safety of a UPS system is thus no longer guaranteed. The necessary autonomous time for a secure shutdown may not be available, which would result in the uncontrolled crash of all consumers.



200 Ah-batteries with BACS in Quasar batterie cabinett



Detail view of single modules. Detection and exchange of defective batteries easily possible.

3. Each battery is individually monitored via a dedicated processor-controlled “RTV” module. This also enables defective batteries on a system to be identified. (Each single battery can be changed instead of the more expensive exchange of whole battery line)

Traditional battery management systems have following restriction: In the case of multiple batteries connected in parallel, only one average voltage value is calculated per block, which can cause individual defective batteries amongst intact ones to be overlooked, thus diminishing the capacity of the entire system.

On some battery management systems, voltage measurements can be set to run over a defined long period with a specified load, but these are of no help in this case.

4. The batteries of a system are charged to the same level, which increases both the overall capacity and the life expectancy of the system.

This eliminates another weak spot of conventional systems: One defective battery can have such a negative impact on the charging behaviour of intact batteries of the system that these too are damaged. The defective battery thus “infects” the others.

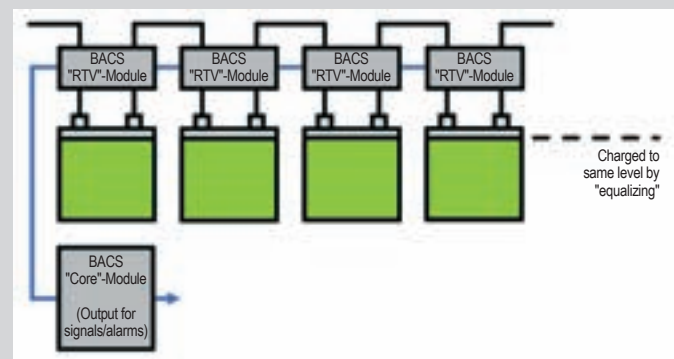

Fig. 3: All batteries attain the same charging level at the end of the charging process, avoiding overcharging or deep discharging of individual batteries and optimising overall capacity.

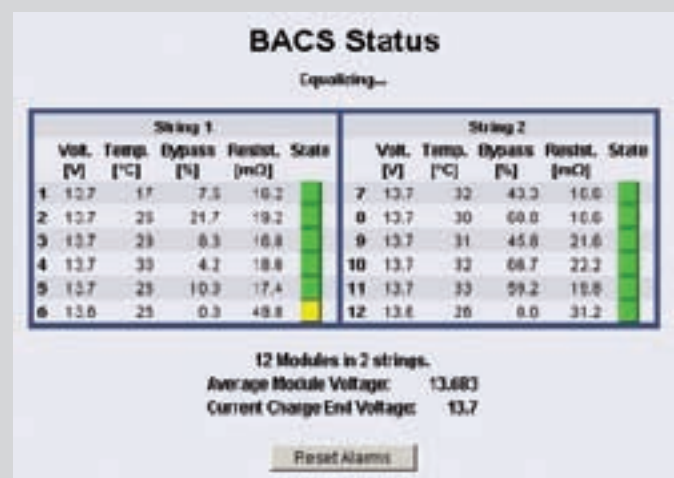

Fig. 4: Remote monitoring of battery systems via BACS and monitoring software increases the system's stability

BACS

Structure of the overall BACS system:

All batteries in the system are equipped with a control unit (data collection, battery controller) – the “RTV” module.

The bus system guides all data to the BACS nerve centre, the core module. This handles the entire management of the battery pack including signal output.

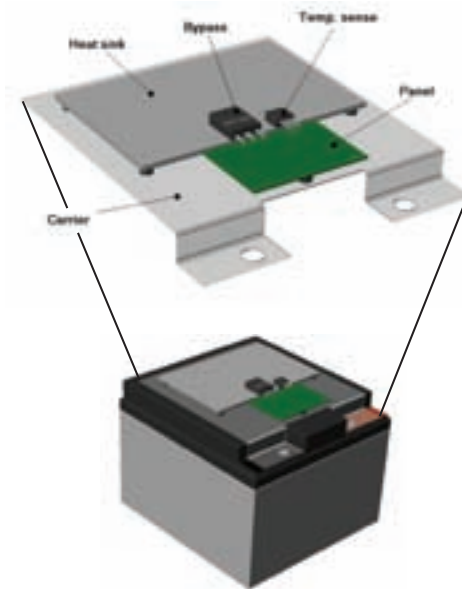

Detailed functions of the RTV module:

Protection Circuit:

Protects the battery module from over-voltage by destroying an irreversible fuse (conducting path).

Ri-Measure:

Measuring channel and signal conditioning of the internal resistance measurement. Measurement is only active when no equalizing (bypass switched off) occurs.

Voltage Measure:

Measuring channel for voltage measurement.

Bypass:

The bypass channel enables a cross-flow that is used both for equalizing and as an offset-signal generator. Appropriately deployed resistances serve as a fuse in the case of a bypass short circuit.

Temp. Measure:

A sensor outside the board records the battery temperature. These data are important for monitoring whether the thermal range of application is adhered to and at the same time to initiate any necessary corrections, e.g. of the final charging voltage.

Controller:

The controller records, controls and processes all signals and data. Additionally, it secures data exchange via the communication channel.

Indication:

The integrated LED displays the operational readiness of the module via a flashing signal. Other optical messages are conceivable.

Communication Port:

The galvanically isolated communication channel enables data exchange with parent systems; the connection enables all subscribers to listen, and just one replies to the central module.

Heat sink:

The electrical energy generated via e.g. equalizing is dissipated as heat.

Carrier:

A carrier for affixing each RTV module is adapted to each battery type.

Panel:

Board for the RTV module electronics.

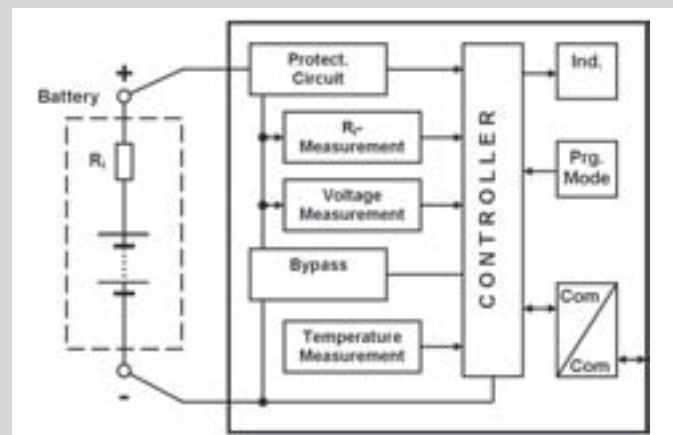

Classification of the RTV modules

The battery modules (RTVC001 to RTVC004) are designed exclusively for lead batteries with a nominal connection voltage of 12V. The description section CXXX specifies the corresponding capacity class.

This guarantees that the module type (RTVCXXX) is suited to the intended battery capacity. The following RTV modules are available:

Class:	Capacity range: (battery capacity)	Resistance range: (internal resistance measurement)	IB/[A]*	IP/[A]**
C001	7 – 12Ah	1.1 – 110mΩ	0 – 0.1	0.2
C002	>12 – 28Ah	1.0 – 100mΩ	0 – 0.3	0.6
C003	>28 – 65Ah	0.6 – 60mΩ	0 – 0.8	1.6
C004	>65 – 200Ah	0.3 – 30mΩ	0 – 3	4.6

Module C004



Single module



detail: board with temperature sensor



Modules integrated into battery line

Module C001



Single module



Modules integrated into battery line



Battery line on rail prepared for integration into a Quasar

Single batteries



Module C003 on BTL12-45 battery



Module C004 on BTL6-100 battery

BACS



Descriptions of the core GX module (BACS Webmanager)

The BACS WEBMANAGER is the core of BACS. The module both provides the link to parent systems (PC, server, web) and also controls all battery modules located in the system. The collected data are managed and saved, and statuses are correspondingly displayed or signalled. The text output on the display is limited to a few messages (several alarms or statuses or current actions). Important data are transferred to the parent WEBMANAGER system and statistically processed accordingly.

The BACS WEBMANAGER can manage up to 150 modules. The BACS WEBMANAGER is supplied as an external unit in its own housing. The “bare” BACS WEBMANAGERS (without casing) can be installed inside the unit if customers require this version. The BACS WEBMANAGER can thus be directly integrated into a UPS or battery pack, for instance.

In summary, the BACS Webmanager provides the following functions:

- Management of all BACS modules/ communication with up to 150 modules (module bus)
- Simple display of the operating statuses/ alarms via the LCD display (16x2 key for scrolling in the display, LED for optical control of the function and as a warning notice (red “fault” LED)
- Acoustic signalling
- Alarm output (relay contact)
- “Real-time clock” for linking/ measuring time and data
- Bulk storage (CF card) for archiving the data over a long period (min. 2-10 years, depending on the size of the CF card)
- Hardware and software “watchdog” for monitoring the Webmanager’s own operating safety. Signal output via alarm contact
- Ports provided: 2x RS232, 1x Ethernet
- 5V DC input for general module power supply
- I²C bus between the web target, the peripheral manager and the BACS modules

BACS and communication via the Webmanager

Software and functional scope:

As a rule the CS121 chip takes precedent over the entire functionality of the core GX module. The CS121 chip essentially handles administration in the same way as the classic USV CS121 SNMP web adapter, the difference being that a BACS system is monitored in this case.

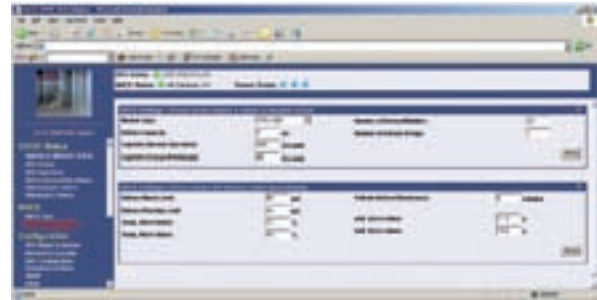

The web browser is also used to set the battery parameters to adapt each module to the specifics of the battery manufacturer.



The web browser displays a warning (yellow) for batteries that are weak or about to fail. As soon as a certain threshold value is crossed, the symbol turns red and a system alarm is activated (acoustically and via the network, e.g. as an e-mail).

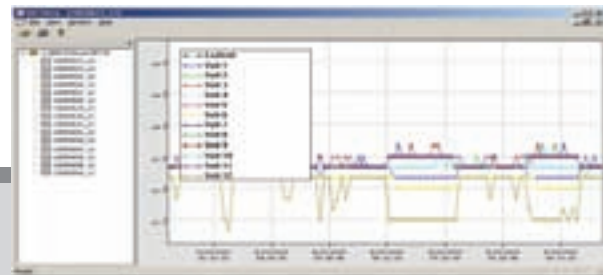

For the graphical evaluation of the data, either a custom EXCEL file can be created or the user can use the BACS VIEWER, an external Windows program that can read the data across the network and display them graphically. BACS VIEWER is available as freeware.

Specifications

BACS module:RTV C001 xxxx:	RTV C001 xxxx:	RTV C002 xxxx:	RTV C003 xxxx:	RTV C004 xxxx:
Input voltage (nominal):	12V	12V	12V	12V
Input voltage range:	7–23V	7–23V	7–23V	7–23V
Precision (V measurement):	<0.5%	<0.5%	<0.5%	<0.5%
Valid block voltage range:	9V <U _{Block} <15V	9V <U _{Block} <15V	9V <U _{Block} <15V	9V <U _{Block} <15V
"Shut off"- current (RTV):	8V	8V	8V	8V
Module power consumption:	Approx. 100mW	Approx. 100mW	Approx. 100mW	Approx. 100mW
Battery capacity:	7–12Ah	12 – 28Ah	28–65Ah	65–200Ah
Battery type:	Lead: vlies, gel	Lead: vlies, gel	Lead: vlies, gel	Lead: vlies, gel
Max. bypass current eff. (equalise):	0.1A	0.3A	0.8A	3A
Bypass current (R meas.):	0.2A	0.6A	1.6A	4.6A
Internal resistance (nominal):	20–13mΩ	13–7mΩ	7–4mΩ	4–2.7mΩ
Internal resistance measurement range:	1.1–110mΩ	1.0–100mΩ	0.6–60mΩ	0.3–30mΩ
Precision (R measurement) :	<3%	<3%	<3%	<3%
Operating temperature:	T _U [0–55]°C	T _U [0–55]°C	T _U [0–55]°C	T _U [0–55]°C
Temperature measurement range:	T _{Range} [-5–60]°C	T _{Range} [-5–60]°C	T _{Range} [-5–60]°C	T _{Range} [-5–60]°C
Valid temperature range:	T _{Block} [0–45]°C	T _{Block} [0–45]°C	T _{Block} [0–45]°C	T _{Block} [0–45]°C
Precision (T measurement) :	<4%	<3%	<3%	<3%
Communication / level:	Serial, RS232 / 5V	Serial, RS232 / 5V	Serial, RS232 / 5V	Serial, RS232 / 5V
Communication speed:	4800 baud	4800 baud	4800 baud	4800 baud

DC UPS DIN rail



12VDC–48VDC, 150-500W

For installation in electrical control cabinets, on DIN rails or anywhere that protected 24V (or 12V and 48V) is required; for instance for entry-control systems, manufacturing and process control systems.

The EFFEKTA® battery with 7/12/18Ah is connected to the UPS and supplies fully uninterrupted load up to the end of cell voltage in case of a mains failure. The battery is optionally available in a DIN optional rail cabinet.

Features

- Compact construction
- Redundant parallel switching possible from 300W
- Alarm outputs for mains fail, battery low and remote off
- Output voltage internally adjustable for low-maintenance and maintenance-free battery types
- Temperature-regulated charging voltage
- Status indication with LEDs
- Surge protection



Specifications

Specification	DC UPS on DIN rail									
	DT0/012		DT0/024				DT0/048			
Input voltage	90...264VAC, 47...63Hz									
Output voltage (nominal)	12V		24V				48V			
Output voltage (physical)	13.6V		27.2V				54.4V			
L.V.D. threshold	10.5V		21V				42V			
Output current nominal	12A	21A	5.6A	7.4A	11A	18A	3A	4.2A	6.25A	10A
Power (w/o battery)	144W	252W	134W	178W	264W	432W	144W	202W	300W	480W
Recommended batt. capacity	5...18Ah									
Dimensions (H x W x D in mm)	105x210x85		105x210x85		133x240x85	133x250x85	105x210x85		133x240x85	133x250x85
Weight (w/o battery)	1.6kg	1.6kg	1.6kg	1.7kg	2.3kg	2.8kg	1.6kg	1.7kg	2.3kg	2.8kg
Operating temperature	0...40°C, battery up to +30 °C									
Signals	Dry contacts: Mains fault, dc low voltage									
Displays	LED green "Operation", red LED "Mains fault", red LED "Battery weak"									
Service	Switch for: "Output on/off", "Automatic restart on/off"									
Safety	EN60950, EN50091-1-2									
EMI	EN61000-6-1, EN61000-6-3									



BT 12-5 (5Ah)



BT 12-12 (12Ah)



BT 12-7.2 (7.2Ah)



BT 12-18 (18Ah)

Batteries	Dimensions / weight (H x W x L in mm)	L.V.D. voltage	Back-up time in minutes at load (current)									
			2A	4A	6A	8A	10A	12A	14A	16A	18A	20A
5Ah	107 x 70 x 90 / 2.1kg	10.5V	105	50	25	15	7					
	2x (107 x 70 x 90) / 4.2kg	21V										
	4x (107 x 70 x 90) / 8.4kg	42V										
7.2Ah	101 x 65 x 151 / 2.7kg	10.5V	150	65	38	25	20	13	7			
	2x (101 x 65 x 151) / 5.4kg	21V										
	4x (101 x 65 x 151) / 10.8kg	42V										
12Ah	101 x 98 x 151 / 4.2kg	10.5V	295	140	84	54	39	31	25	20	18	
	2x (101 x 98 x 151) / 8.4kg	21V										
	4x (101 x 98 x 151) / 16.8kg	42V										
18Ah	167 x 88 x 181 / 5.7kg	10.5V	470	200	121	93	66	48	40	34	29	26
	2x (167 x 88 x 181) / 11.5kg	21V										
	4x (167 x 88 x 181) / 23kg	42V										

DC power supply

DC ST601

-48 / 60V power supply system including:

- 1U 19IN shelf
- Max. 2 x 600W rectifier
- Power distribution
- Controller



Description

The DC ST601 power supply system is designed for various applications such as digital access, wireless base stations, microwave links as well as PABX. Numerous options provide solutions for global applications in different environments.

The integrated modular power system allows flexible adaptations. It contains up to 2 rectifiers GR 600 with 48 or 60V, AC- and up to 6 separate protected DC-connections, battery fuses LVD, and power system controller. These features together with the very short depth are the key factors for the success of this power system, offering cost-effective and reliable solutions.

This compact and high density power supply system is the perfect choice for space-critical locations.



Rear view

Main features

- 19" / 1U shelf power system up to 1200W
- High power density
- Very short depth
- Fits into 300mm deep ETSI cabinets
- Fan cooled rectifiers GR 600 (48 or 60V)
- Integrated power distribution
- Easy installation
- Dimensions (h x w x d) 44.45 x 430 x 280mm

Applications

- DC UPS systems
- Digital subscriber line (DSL)
- Fiber in the loop
- Transmission
- PBX
- Network components

Specifications

Optional accessories

Software
Programming cable
Blank panel



Right hand picture: rear view of rectifier module GR 600

On the far right: front view of rectifier module GR 600

General	48V-version	60V-version
Efficiency	≥92%	≥92%
EMI, radiated	EN 55 022, class B	EN 55 022, class B
Safety	EN 60 950, class I	EN 60 950, class I
Cooling	Fan cooled	Fan cooled
Protection	IP 20	IP 20

Input	48V-version	60V-version
AC connection	1 x L/N/PE	1 x L/N/PE
Nominal voltage	230 V _{rms}	230V _{rms}
Voltage range	80 ... 300V _{rms}	80 ... 300V _{rms}
Voltage range, reduced power	80 ... 130V _{rms}	80 ... 130V _{rms}
Frequency range	50 / 60Hz	50 / 60Hz
Current nominal	5.8A _{rms}	5.8A _{rms}
Current maximum	12A _{rms}	12A _{rms}
Line current	Meets IEC 1000-3-2	Meets IEC 1000-3-2
Mains terminal	Common terminal	Common terminal
Transient OVP	Optional / external	Optional / external

Output	48V-version	60V-version
Voltage, nominal	-48V _{dc}	-60V _{dc}
Voltage range	-42 ... -58V _{dc}	-52 ... -72V _{dc}
Output current	25A _{dc}	20A _{dc}
Current limitation	28A _{dc}	22A _{dc}
Power, limitation	2 x 600W	2 x 600W
Power, nominal	1200W	1200W
Power, redundant	600W	600W
Power, at 88Vrms	800W	800W

Load distribution	48V-version	60V-version
Fuses (DIN 72581-3)	4 pieces / 1 ... 30A	4 pieces / 1 ... 30A
PLD	None	None

Battery connection	48V-version	60V-version
Fuses (DIN 72581-3)	2 pieces / 40A	2 pieces / 40A
LVD	60A	60A

Mechanics	48V-version	60V-version
Construction	Steel rack	Steel rack
Cabinet standard	19IN	19IN
Width	430mm	430mm
Depth, overall	280mm (including handles)	280mm (including handles)
Height, overall	44.45mm (1U)	44.45mm (1U)
Weight, system	5kgs / 11lb (excluding rectifier)	5kgs / 11lb (excluding rectifier)
Weight, rectifier	0.9kg / 2.0lb	0.9kg / 2.0lb

Environment	48V-version	60V-version
Operation temperature	-25 ... +65°C	-25 ... +65°C
Relative humidity	95% max., non condensing	95% max., non condensing

Control and monitoring	48V-version	60V-version
Controller	PSC 1 / 3	PSC 1 / 3
See brochure/data sheet of power system controller		

DC power supply

DC ST602

-48 / 60V power supply system including:

- 2U 19IN shelf
- Max. 4 x 600W rectifier
- Power distribution
- Controller



Description

The DC ST602 power supply system is designed for various applications such as digital access, wireless base stations, microwave links as well as PABX. Numerous options provide solutions for global applications in different environments.

The integrated modular power system allows flexible adaptations. It contains up to 4 rectifiers GR 600 with 48 or 60V, AC- and up to 16 DC-connections, battery connection and power system controller. These features together with the very short depth are the key factors for the success of this power system, offering cost-effective and reliable solutions.

This compact and high density power supply system is the perfect choice for space-critical locations.



Rear view

Main features

- 19" / 2U shelf power system up to 2400W
- High power density
- Very short depth (fits into 300mm deep ETSI cabinets)
- Parallel redundant operation mode applicable
- Fan cooled rectifiers GR 600 (48 or 60V)
- Integrated power distribution
- Easy installation and programming
- Dimensions (h x w x d) 88 x 430 x 282mm

Applications

- DC UPS systems
- Digital subscriber line (DSL)
- Fiber in the loop
- Transmission
- PBX
- Network components



Upper left picture: Modular design with up to 4 rectifiers

Lower left picture: model with automatic circuit breakers (purpose-built item)

Right hand picture: rectifier GR 600



Specifications

General	600W - 48V	600W - 60V
Efficiency	≥92%	≥92%
EMI, radiated	EN 55 022, class B	EN 55 022, class B
Safety	EN 60 950, class I	EN 60 950, class I
Cooling	Fan cooled	Fan cooled
Protection	IP20	IP20

Input	600W - 48V	600W - 60V
AC connection	1 x L/N/PE	1 x L/N/PE
Nominal voltage	230V _{rms}	230V _{rms}
Voltage range	80 ... 300V _{rms}	80 ... 300V _{rms}
Voltage range, reduced power	80 ... 130V _{rms}	80 ... 130V _{rms}
Frequency range	50 / 60Hz	50 / 60Hz
Current nominal	11,5A _{rms}	11,5A _{rms}
Current maximum	24A _{rms}	24A _{rms}
Line current	Meets IEC 1000-3-2	Meets IEC 1000-3-2
Mains terminal	Common terminal	Common terminal
Transient OVP	Optional / external	Optional / external

Output	600W - 48V	600W - 60V
Voltage, nominal	-48V _{dc}	-60V _{dc}
Voltage range	-42 ... -58V _{dc}	-52 ... -72V _{dc}
Output current	50A _{dc}	40A _{dc}
Current limitation	56A _{dc}	44A _{dc}
Power, limitation	4 x 600W	4 x 600W
Power, nominal	2400W	2400W
Power, redundant	1800W	1800W
Power, at 88Vrms	1600W	1600W

Load distribution	600W - 48V	600W - 60V
Fuses (DIN 72581-3)	16 pieces / 1... 20A	16 pieces / 1... 20A
PLD	None	None

Battery connection	600W - 48V	600W - 60V
Fuses (DIN 72581-3)	2 pieces / 50A	2 pieces / 50A
LVD	60A	60A

Mechanics	600W - 48V	600W - 60V
Construction	Steel rack	Steel rack
Cabinet standard	19IN	19 IN
Width	430mm	430mm
Depth, overall	282mm (including handles)	282mm (including handles)
Height, overall	88.9mm (2U)	88.9mm (2U)
Weight, system	5kg / 11lb (excluding rectifier)	5kg / 11lb (excluding rectifier)
Weight, rectifier	0.9kg / 2.0lb	0.9kg / 2.0lb

Environment	600W - 48V	600W - 60V
Operation temperature	-25 ... +65°C	-25 ... +65°C
Relative humidity	95% max., non condensing	95% max., non condensing

Control and monitoring	600W - 48V	600W - 60V
Controller	PSC 1 / 3	PSC 1 / 3

Optional accessories		
Software		
Programming cable		
Dummy cover		

GR 600 600

Rectifier 48 / 60V, 600W

Left hand image: rear view
Right hand image: front view



Description

GR 600 is a single phase, hot-pluggable, fan-cooled rectifier. The outstanding power density of this product offers the optimum shelf solutions with 1U shelf DC ST601 and 2U shelf DC ST602.

The short depth and extended operating temperature range support compact installation in space critical pole-mount applications. The high efficiency supports the operator's effort for energy saving for the backup power solution and requires less cooling energy due to the low losses. The very low audible noise is the key factor for installations in urban areas. Together with the advanced controller, the power solution offers additional benefits to optimize the running cost of the total site.

The typical applications for this rectifier are both in indoor and outdoor environments, which is a perfect solution for digital subscriber line (DSL), transmission, wireless infrastructure, core network components, telecommunication networks and data networks.

Main features

- Space saving - Very high power density (up to 14W/in³)
- Energy saving - High efficiency up to 92%
- Easy installation - Hot pluggable, connectors at the rear
- Low audible noise - Fan cooled with speed control
- Wide input voltage range 80 ... 300V_{rms}
- Protection against loss of Neutral and AC overvoltage
- Power factor correction - Sinusoidal input current
- Optimized power availability to recharge batteries - Constant output power characteristic
- Operating temperature range up to 75°C (167°F)

Applications

- Digital subscriber line (DSL)
- Transmission, PBX
- Fiber in the Loop
- Wireless base stations, Network components

Specifications

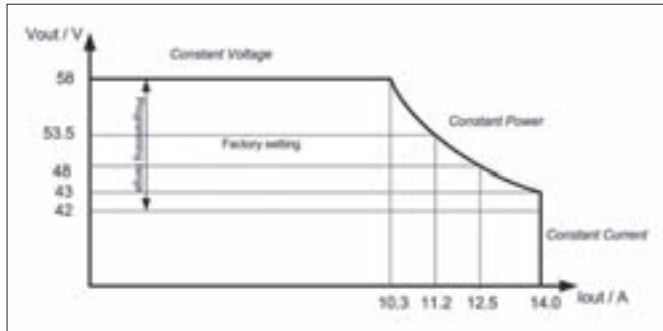

Top picture:
Output characteristics 600W, 48V

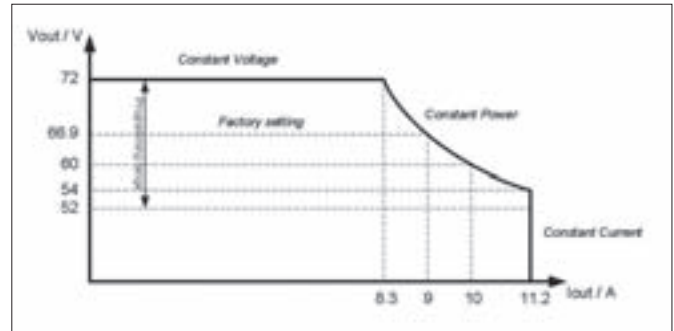

Top picture:
Output characteristics 600W, 60V

General	600W, 48V	600W, 60V
Efficiency	≥92%	≥92%
Losses max.	90W	90W
Safety	IEC 60 950, class I UL 60 950 CAN / CSA – C22.2	EN 60 950, class I UL 60 950 / CAN / CSA – C22.2
EMI, radiated	EN 55022, class B	EN 55022, class B
Compliant with	ETSI EN 300386	ETSI EN 300386
Cooling	Fan cooled	Fan cooled
Power density	14W/in ³	14W/in ³
Acoustic noise	50dB(A)	50dB(A)

Input	600W, 48V	600 W, 60 V
Voltage range	80 ... 300V _{rms}	80 ... 300V _{rms}
Volt. range, red. power	80 ... 184V _{rms}	80 ... 184V _{rms}
Inrush current	20A _{peak}	20 _{peak}
Current maximum	6A _{rms}	6A _{rms}
Line current	IEC 1000-3-2	IEC 1000-3-2
Harmonic distort. THD	< 5%	< 5%
Power factor	~ 1.0	~ 1.0
EMI, conducted	EN 55022, class B	EN 55022, class B
Mains connector	Rear side	Rear side
Input protection	Internal fuse 2 x 8A	Internal fuse 2 x 10A
Input switch	None	None
AC overvoltage protection	Incl. loss of neutral	Incl. loss of neutral

Output	600 W, 48 V	600 W, 60 V
Voltage, nominal	53,5V _{dc}	66,9V _{dc}
Volt. adjust range	42 ... 58V _{dc}	52 ... 72V _{dc}
Voltage regulation	±250mV _{dc}	±250mV _{dc}
Overvoltage protection	59±1V _{dc}	73±1V _{dc}
Ripple + Spikes	≤100mV _{p-p}	≤100mV _{p-p}
Psophometric noise	≤1.5mV _{rms} (weighted)	≤1.5mV _{rms} (weighted)
EMI, conducted	EN 55022, class A	EN 55022, class A
Current limit, nom.	14A _{dc}	11,2A _{dc}
Limit adjustment range	0 ... 14A _{dc}	0 ... 11,2A _{dc}
Load sharing	<±1A _{dc}	<±1A _{dc}
Power limit	600W, fixed	600W, fixed
Output connector	Rear side	Rear side
Output protection	Internal fuse 20 A	Internal fuse 20 A

User interface	
Output current display	LED-bar
Status indication	LED «ok» LED «OVP»* LED «Over temp»* LED «Fan failure»* *Indications in LED bar

Systemcontroller	
PSC 1000	Voltage programming Rectifier fail alarm
PSC 1 / 3 (See brochure/data sheet of power system controller)	Voltage programming Current limit programming Power limit programming Rectifier fail alarm Rectifier start up Rectifier on/off Separate charge



Right hand picture:
System controller PSC 1

Environment	
Temperature	-25 ... +75°C (-13 ... +167°F)
Power derating	+65 ... +75°C (+149 ... +167°F)
Relative humidity	95% max., non condensing

Mechanics	600 W, 48 V	600 W, 60 V
Width, overall	40.5mm (1U)	40.5mm (1U)
Height, overall	86.4mm (2U)	86.4mm (2U)
Depth, overall	231.9mm	231.9mm
Weight	0.9kg	0.9kg

DC power supply

DC ST1603

-48 V power supply system consisting of:

- 3U Shelf
- Max. 4 x 1600W rectifiers
- Power distribution
- Controller



Description

The DC ST1603 is a power supply system for -48V with a maximum power up to 6400W with 3-phase input.

The integrated modular power system allows flexible adaptations. It contains up to 4 rectifiers of type GR 1600, AC- and DC-connections, battery connection and power system controller PSC 1 / PSC 3. Other configurations are available on request.

These features together with the very compact depth are the key factor for the success of this power system and it offers cost-effective and reliable solutions.

This power supply system is designed for various applications such as digital access, wireless base stations, microwave links as well as PABX. Feel free to ask for individual solutions.

Features

- Modular design
- 19"- 3U rectifier-shelf (standard) + controller PSC1/3
- Easy connecting and mounting of shelf
- Fan cooled rectifiers GR 600 (48 or 60V)
- Hot pluggable
- All connectors at the rear
- Efficiency $\leq 92\%$
- Integrated power distribution

Applications

- Digital subscriber line (DSL)
- Transmission
- PBX
- Wireless base stations
- Network components

Specifications

Optional accessories	
Software	
Programming cable	
Dummy cover	

Options	
Number of rectifiers	1 ... 4
AC connections	3L+PE (220 / 240V _{rms} L-L)* L + N + PE
Display	System voltage, current
Transient OVP	for 3L + N + PE (external)



Right hand picture:
Rectifier GR 1600

General	
Efficiency	≥ 91 %
EMI, radiated	EN 55 022, class B
Safety	EN 60 950, class I
Cooling	Fan cooled

Input	
AC connection	3 x L + N/PE
Nominal voltage	3 x 230 / 400V _{rms}
Voltage range	88 ... 300V _{rms}
Range, reduced power	88 ... 184V _{rms}
Frequency range	50 / 60Hz
Current nominal / phase (4 rectifiers)	19A
Current maximum	< 30A _{peak}
Line current	meets IEC 1000-3-2
EMI, conducted	EN 55 022, class B
Mains terminal	Terminal Block
Transient OVP	Optional / extern

Output	
Voltage, nominal	53.5V _{dc}
Voltage adjust range	42 ... 58V _{dc}
Voltage error, static	± 250mV _{dc}
Overvoltage protection	59V ± 1V
Ripple + Spikes	≤ 200mV _{p-p}
Psophometric noise (weighted)	≤ 1.0mV _{rms}
EMI, conducted	EN 55 022, class A
Power, nominal (4 rectifiers)	6400W
Power, redundant (3 rectifiers)	4800W

Load distribution	
Fuses (DIN 72581-3)	9 MCBs, 1 ... 63A
LVLD	no

Battery connection	
Fuses (DIN 72581-3)	2 MCBs, 125A max.
LVD	Optional

Mechanics	
Construction	Steel rack
Cabinet standard	19IN
Width, body	450.5mm
Depth, overall	272mm (incl. grab handle)
Height, overall	133mm (3U)
Weight, system	9 kg (without rectifiers)
Weight, rectifier	1.25kg each

Environment	
Operation temperature	-25 ... +65°C
Operation temperature (reduced power)	65 ... +75°C
Relative humidity	95% max., non condensing
Protection	IP 20

Control and monitoring	
Controller	PSC 1 / 3
See brochure/data sheet of power system controller	

GR 1600

Rectifier 48V, 1600W

Left hand image: rear view
Right hand image: front view



Description

GR 1600 is a single phase, hot-pluggable, fan-cooled 48V rectifier. The outstanding power density of this product offers the optimum 1U or 3U 19IN shelf solutions.

The short depth and extended operating temperature range support compact installation in space critical pole-mount applications. The high efficiency supports the operator's effort for energy saving for the backup power solution and requires less cooling energy due to the low losses. The very low audible noise is the key factor for installations in urban areas. Together with the advanced controller, the power solution offers additional benefits to optimize the running cost of the total site.

The typical applications for this rectifier are both in indoor and outdoor environments, which is a perfect solution for digital subscriber line (DSL), transmission, wireless infrastructure, core network components, telecommunication networks and data networks.

Main features

- Space saving - Very high power density 24W/in³
- Energy saving - High efficiency 92%
- Easy installation - Hot pluggable, connectors at the rear
- Low audible noise - Fan cooled with speed control
- Wide input voltage range: 88 - 300Vrms
- Protection against loss of Neutral and AC overvoltage
- Power factor correction - Sinusoidal input current
- Constant output power characteristic
- Operating temperature range up to 75°C (167°F)

Applications

- Digital subscriber line (DSL)
- Transmission, PBX
- Wireless base stations, Network components

Specifications

Optional accessories	
Single backplane	D0106218
Triple backplane	D0112006
Blank panel	D0112127

Environment	
Temperature	-25 ... +75°C (-13 ... +167°F)
Power derating	+65 ... +75°C (+149 ... +167°F)
Relative humidity	95% max., non condensing

Mechanics	
Width, overall	40.8mm (1.6in, 1U)
Height, overall	132mm (5.2in, 3U)
Depth, overall	232.5mm (9.15in)
Weight	1.25kg (2.75lb)

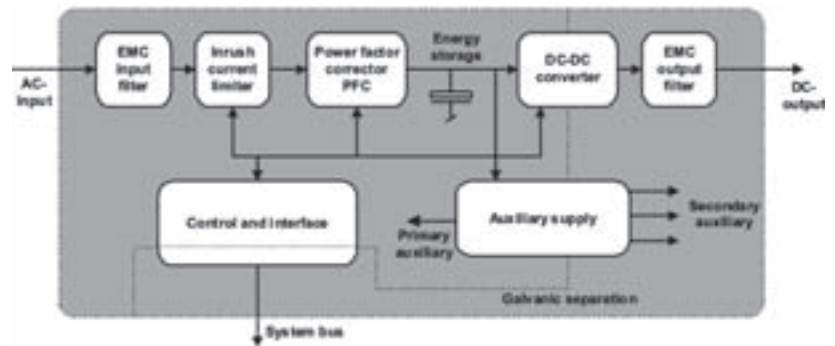

Top image: Block diagram

General	
Efficiency	92%
Losses max.	180W
Safety	IEC 60 950, class I UL 60 950 CAN / CSA – C22.2
EMI, radiated	EN 55022, class B
Compliant with	ETSI EN 300386
Cooling	Fan cooled
Power density	24W/in ³
Acoustic noise	48dB(A)

Input	
Voltage range	85 ... 300V _{rms}
Volt. range, red. power	85 ... 184V _{rms}
Inrush current	15A _{peak}
Current maximum	9,5A _{rms}
Line current	IEC 1000-3-2
Harmonic distort. THD	5%
Power factor	~ 1.0
EMI, conducted	EN 55022, class B
Mains connector	Rear side
Input protection	Internal fuse 2 x 15A
Input switch	None
AC overvoltage protection	Incl. loss of neutral

Output	
Voltage, nominal	53,5V _{dc}
Volt. adjust range	42 ... 58V _{dc}
Voltage regulation	±250mV _{dc}
Overvoltage protection	59±1V _{dc}
Ripple + Spikes	≤100mV _{pp}
Psophometric noise	≤1.5mV _{rms} (weighted)
EMI, conducted	EN 55022, class A
Current limit, nom.	33,4A _{dc}
Limit adjustment range	0 ... 33,4A _{dc}
Load sharing	<±2A _{dc}
Power limit	1600W, fixed
Output connector	Rear side
Output protection	Internal fuse 40A

User interface	
Output current display	LED-bar
Status indication	LED «ok» LED «OVP»* LED «Over temp»* LED «Fan failure»* *Indications in LED bar

System controller	
PSC 1000	Voltage programming Rectifier fail alarm
PSC 1 / 3 (See brochure/data sheet of power system controller)	Voltage programming Current limit programming Power limit programming Rectifier fail alarm Rectifier start up Rectifier on/off Separate charge

Output characteristic:

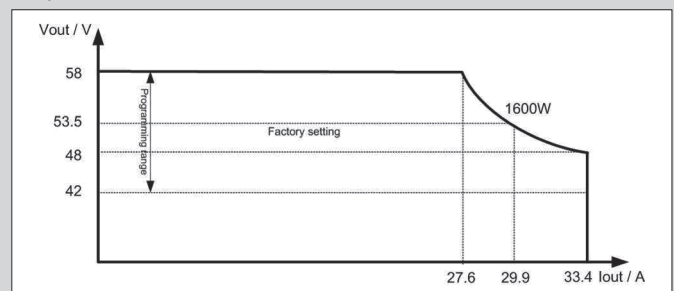

'Golden finger' connector for reliable 1:1 connection to the system bus

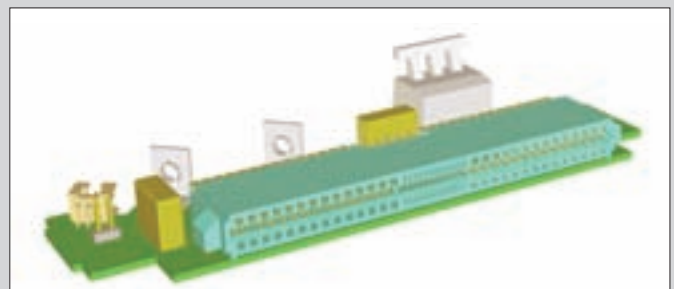

DC power supply

DC ST2010

-48 / 60V power supply system consisting of:

- 5U shelf for power distribution and controller
- 5U shelf for max. 6 x 2000W rectifiers

Left hand picture:

rear view

Right hand picture:

front view

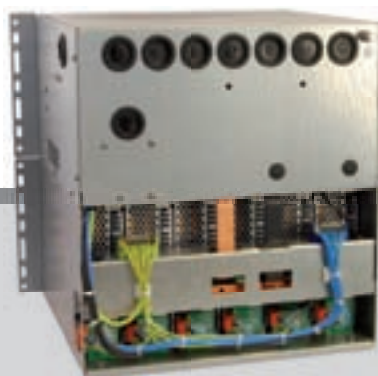

Description

The DC ST2010 is a very compact 19" / 5U shelf for the rectifier GR 2000 with a maximum power of 12kW and three phase input.

Due to the modular design the DC ST2010 can be assembled with up to 6 rectifiers GR 2000. In the power distribution unit there also can be found the controller, LVD/PLD, current sensors, battery fuses and up to 15 separately protected DC-outputs. Other configurations can be easily developed on demand.

These are the key factors of the success of this power system and it offers a cost-effective and reliable solution.

The typical applications for this rectifier shelf are both in indoor and outdoor environments, which is a perfect solution for wireless base stations, core network components, telecommunication networks and data networks. Please feel free to ask for individual solutions.

Main features

- Modular structure
- 19" rectifier shelf / 5U
- Easy to stack shelves
- Up to 12 kW installed power
- Fan cooled rectifiers FR 48V – 2000W – E
- Hot pluggable, all connectors at the rear
- Efficiency $\geq 92\%$
- Integrated 3 phase AC terminal (3L + N + PE)

Applications

- Indoor and outdoor
- Medium to large power systems
- Shelf power solutions
- Telecom, wireless, Datacom

Specifications

Options	
Max. number of rectifiers	1 ... 6
AC connection	3L + N + PE 3L + PE (220 / 240V _{rms} L-L)*
DC outputs	max. 15

*on request

Optional accessories	
Software	
Programming cable	
Dummy cover	



Right hand picture: rear view GR 2000

On the far right: front view GR 2000

General	
Efficiency	≥ 92%
Losses, max.	1200W (6 rectifiers)
Safety	IEC/EN 60 950
EMC	EN 300 386-2
Cooling	Fan cooled rectifiers
Protection	IP 20

Input	
AC connection	3L + N + PE
Nominal voltage	3 x 230 V _{rms} (L-N)
Range, full power	184 ... 300V _{rms}
Range, reduced power	88 ... 184V _{rms}
Frequency range	45 / 66Hz
Current nominal	3 x 19A _{rms} @ 12kW
Current maximum	3 x 24A _{rms} @ 12kW
Inrush current	< 30A _{peak} each phase
Line current	meets IEC 1000-3-2
Harmonic distort. THD	< 5%
Mains terminal	AC cable 5 x 6mm 2 / 5m
Input protection, recommended	MCB 3 x 25A / C-curve
Main switch	external

Output	
Voltage, nominal	-48 / -60V _{dc}
Voltage range	-42 ... -72V _{dc}
Voltage error, static	± 250mV _{dc}
Overvoltage protection	59 / 71V ± 1V
Ripple + Spikes	≤ 200mV _{p-p}
Psophometric noise	≤ 1.0mV _{rms} (weighted)
Nominal current	224A _{dc} 12kW, 53.5V
Current limit, maximum	279A _{dc} @ 12kW, 43V
Power, nominal	12kW
Power, redundant	10kW
Power, reduced	min. 4800W
Output terminal	Copper bar, rear side
Output protection	Internal fuse each rectifier

Mechanics	
Construction	steel frame
Cabinet standard	19"
Width, body	437mm
Depth, overall	432mm
Height, overall	2 x 225mm (2 x 5U)
Weight, system	20kg
Weight, rectifiers	App. 6 x 4.4kg

Environment	
Operating temperature	-5 ... +45°C
Relative humidity	95% max., non condensing

Control and monitoring	
Controller	PSC 1 / 3
See brochure/data sheet of power system controller	



Right hand picture:
Customers design system:
2 x 24.000W redundant
(24 rectifiers)
in 600x600x2000mm cabinet
with 2 inputs

GR 2000

Rectifier 48/60V, 2000W

Right hand picture: rear view
On the far right: front view



Description

The GR 2000 is an up to date high frequency switched mode telecom power supply for both 48V and 60V applications.

It consists of two power processing stages. The first one is a boost based power factor corrector using the zero current switching technique. The second stage is a phase shifted full bridge DC/DC converter using state-of-the-art soft switching technology.

The GR 2000 offers output characteristic with power limit matching a constant power character of modern telecom loads and thus reducing the required number of rectifiers.

The primary applications of the rectifier are modular power systems for telecommunication equipment.

Main features

- Efficiency $\geq 91\%$
- Compact (500W / l) and light (4.4kg)
- Hot pluggable, all connectors at the rear
- Fan cooled with air flow monitoring
- Wide input voltage range: 88 - 276V_{rms}
- Power factor ~ 1.0 (sinusoidal input current)
- Selectable output voltage 48V or 60V
- Constant output power characteristic
- Analogue system bus
- Operating temperature range up to 70°C

Applications

- Indoor and Outdoor
- Medium to large power systems
- Shelf power solutions
- Telecom, wireless, Datacom

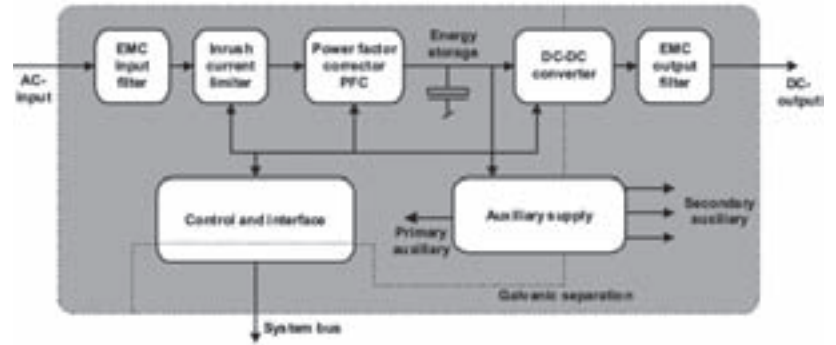

Right hand image:
Block diagram

Specifications

General	
Efficiency	≥ 91%
Losses, max.	200W
Safety	EN 60 950, class I
EMI, radiated	EN 55022, class B
Compliant with	EN 300386-2
Cooling	Fan cooled
Power density	500W/l (8.2W / in ³)

Input	
Voltage range	88 ... 276V _{rms}
Volt. range, red. power	88 ... 184V _{rms}
Inrush current	< 15A _{peak}
Current maximum	12A _{rms}
Line current	According IEC 1000-3-2
Harmonic distort. THD	< 5%
EMI, conducted	EN 55022, class B
Mains connector	Rear side
Input protection	Internal fuse 2 x 15A
Input switch	None

Output	
Voltage, nominal	53.5 / 62V _{dc}
Voltage adjust range	42 ... 72V _{dc}
Voltage regulation	± 250mV _{dc}
Overvoltage protection	58.5 / 73V ± 1 %
Ripple + Spikes	≤ 200mV _{pp}
Psophometric noise	≤ 1.0mV _{rms} (weighted)
EMI, conducted	EN 55022, class A
Current limit, nominal	37A _{dc}
Limit adjustment range	0 ... 37A _{dc}
Load sharing	< ± 3A _{dc}
Power limit	2000W, fixed
Output connector	Rear side
Output protection	Internal fuse 50A

User interface	
Output current display	LED bar
Status indication	LEDs «ok», «Alarm»
Output voltage	Test jack
Output current	Test jack

Power system controller	
PSC 1000	Voltage programming Rectifier fail alarm
PSC 1 / 3 (See brochure/data sheet of power system controller)	Voltage programming Current limit programming Power limit programming Rectifier fail alarm Rectifier start up Rectifier on/off Separate charge

Mechanics	
Width, overall	65mm (2.56in)
Height, overall	212mm (8.35in)
Depth, overall	346mm (13.62in)
Weight	4.4kg (9.7lb)

Environment	
Operating temperature	-25 ... +70°C (-13 ... +158°F)
Power derating	+60 ... +70°C (+140 ... +158°F)
Relative humidity	95% max., non condensing

Optional accessories	
Single backplane	D0100298
Blank panel	D0018281

Output characteristic:

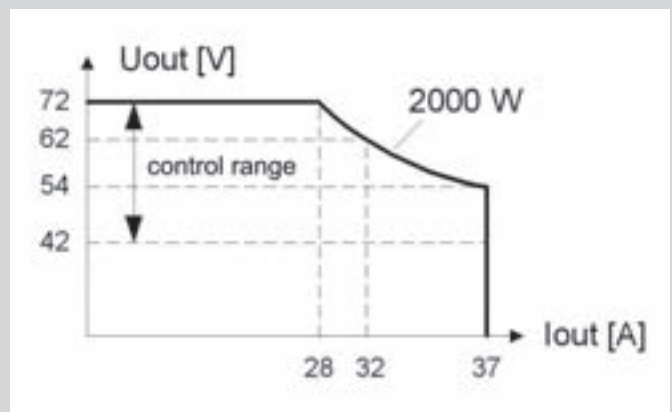

Power System Controller

Controller for power supply systems

DC ST 601 up to DC ST 2010 / rectifiers GR 600 - GR 2000



PSC 1



PSC 3

Description

The PSC 1 is a simple power system controller for small power systems. It consists of a compact central unit providing basic I/O periphery, and of an analogue based communication bus to the rectifiers. The user friendly display quickly displays basic information about the current status of the power system. The controller's battery management with regularly accomplished capacity tests is one of the key factors for the availability of a power system. The PSC 1 controller allows also remote alarming by means of potential-free relay contacts.

Features

- Float voltage control
- Temperature compensation
- Battery current limit
- Boost charge
- Battery test, advanced capacity test
- LVD control
- Analogue system bus
- Simple user interface

Applications

- Power supply systems
- Digital subscriber line (DSL)
- Fiber in the loop
- Transmission
- PBX

Description

The PSC 3 is a 3rd generation power system controller for small to very large and complex power systems. It consists of a central unit, which provides basic I/O periphery, and of a very reliable CAN standard based communication bus. The front end modules are located close to the elements to be monitored. The benefit is an easy wiring, which is perfect for expandable power systems with decentralized distributions (BDFB) and batteries in separate rooms. The integrated PLC offers the flexibility for monitoring and control of auxiliary devices, later functions upgrade and system capacity expansions. The PSC 3 allows remote alarming by means of potential-free relay contacts or via modem or LAN / Ethernet. The SNMP offers enhanced remote alarming and is designed to work with SNMP managers. An integrated web server offers a user friendly interface for detailed monitoring and control with a standard web browser.

Features

- Modular power system controller
- Integrated PLC for flexible system configuration
- Easy system expansion
- Digital system bus
- Enhanced battery management
- Remote monitoring with modem or LAN
- Integrated web server
- SNMP
- Energy saving functions
- New alarming concepts
- Monitoring of auxiliary devices
- Advanced site monitoring & control

Applications

- Power supply systems
- Decentralized power plants

Modular DC power supply systems 48-60V

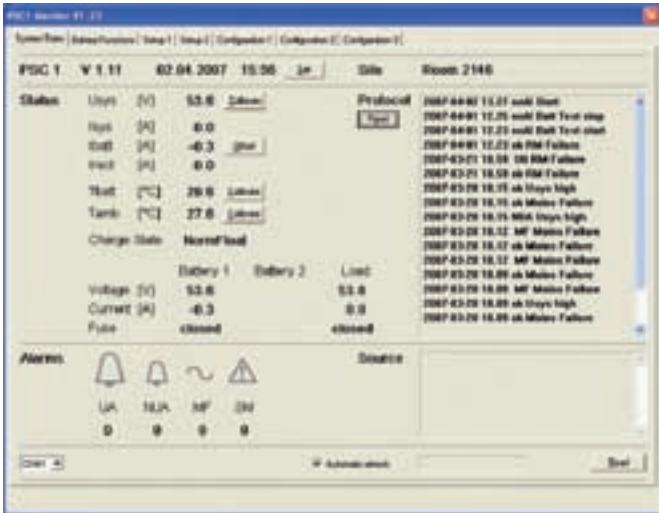

Top picture: «PSC 1 Monitor» - program



Top picture: controlling and monitoring of PSC 3 via WEB browser

General	PSC1	PSC3
Safety	EN 60 950, class I UL 60 950 CAN / CSA – C22.2	EN 60 950, class I UL 60 950 CAN / CSA – C22.2
EMV, radiated	EN 55 022, class B	EN 55 022, class B
Compliant with	EN 300 386-2	EN 300 386-2
Cooling	Convection	Convection
Mounting direction	horizontal / vertical	All
Protection	IP20	IP20

Power supply	PSC1	PSC3
Voltage range	18 ... 75V _{dc}	18 ... 75V _{dc}
Current	50 mA _{dc} max.	0.75 A _{dc} max.
EML, conducted	EN 55 022, class B	EN 55 022, class B
Input protection	Internal fuse	External fuse 2A
Input switch	None	None

Features	PSC1	PSC3
Rectifier interface	Analogue	Digital, CAN-based
Number of rectifiers	Up to 16	Up to 128
Digital input	Up to 4	Up to 225
Relay output	Up to 6	Up to 97
Temperature	2	Up to 96
Voltage, current	Up to 3	Up to 96
Display	LCD	Up to 2 User interface modules
Local monitoring	LCD and RS232	LAN/RS232/WEB Browser
Remote monitoring	None	LAN/Modem/WEB Browser
Remote alarming	Dry contacts	Dry contacts/SNMP
Web server access	None	Up to 4 levels
SNMP management	None	Standard SNMP manager

Mechanics	PSC1	PSC3
Height, body	40.4mm / 1U	43mm / 1.69inch
Width, overall	83.4mm / 2U	86.5mm / 3.41inch
Depth, overall	195mm / 7.7inch	180mm / 7.09inch
Weight	0.3kg / 6.6lb	0.6kg / 13.2lb

Functions	PSC1	PSC3
Float voltage control / Temperature compensation	•	•
Battery middle point		•
Battery block voltage, up to 256		•
Battery current limit, enhanced	•	•
Boost charge	•	•
Equalise		•
Battery test, advanced capacity test	•	•
LVD and PLD functions, up to 96		•
Battery deep discharge protection	•	•
Mains failure detection	•	•
Real time clock		• (optional)
Genset functions		•
Individual rectifier control		•
Efficiency mode / Energy saving		•
Rectifier cycling		•
Sequential startup		•
PLC functionality / event generator		•
200 data log entries		•
Remote function upgrade		•

User interface	PSC1	PSC3
Status indication	LED «Alarm» LCD with backlight Rectifier status indication on each module	LED «ok» LED «alarm»
User interface UIM (option)	None	5 configurable LED LCD display Keypad

Environment	PSC1	PSC3
Operating temperature	-40 ... +75°C -40 ... +167°F	-35 ... +60°C -31 ... +140°F
Relative humidity	95% max., non condensing	

Options	PSC1	PSC3
	None	User Interface Module UIM with LCD display and keys Modem interface RS 232 Real time clock
	Configuration software	
	Programming cable	

DC-UPS systems



Product Description

The DC Power Rack DCPR 48-66 is specifically designed for use in telecommunications networks. Fuse-protected 48V power supplies from EFFEKTA® are already in successful operation in TETRA and TETRAPOL networks. Available versions: 108V and 216 VDC.

Up to 4 rectifier modules PSR308 can be integrated into the subrack. The unit is equipped with a supervisory module combined with a fan tablet and DC distribution.

Key Features

- High reliability
- Simple installation and operation
- Forced fan cooling
- USB interface for PC connection
- Alarm contacts for multiple configurations
- Intelligent battery management
- CAN-Bus interface
- Hot pluggable controller and DC distribution modules
- Optional Ethernet (SNMP compatible) interface module
- LVD and PLD functionality



Front view of DCR PSR 327-10.8

System Components



Rectifier module PSR327:
110 / 220VDC; 2700W; 12.9A / Key Features:

- Single-phase modul with sinusoidal input current (PFC)
- Input overvoltage protection
- Wide input voltage range (100-254 VAC)
- „Hot-Plug-In“ design with backplane connection
- High power density
- CAN- Bus interface
- Integrated decoupling from the DC bus



Control Unit UPC3 with integrated fan
Key Features:

- Extensive battery management
- Freely programmable signalling concept
- „Hot-Plug-In“ design with backplane connection
- Integration of external alarm structures possible
- Remote control. + monitoring via direct PC link, modem or SNMP
- CAN- Bus interface

Specifications

Type	DCR PSR327-xxx
Input voltage	230VAC
Output voltage	110 / 220VDC
Output capacity	8100 / 10800W
Mains	3 phases, N, PE
DC output	Screw connection M10
Analog inputs	3 x shunt (60mV); 2 x temperature sensor 1 x battery tapping point, analog inputs on ext. connector board sensor lead for output voltage
Signalling input	8 x potential-free, common ground
Signalling output	6 isolated relay contacts
Climatic conditions	Acc. IEC 721-3-3 Klasse 3K3/3Z1/3B1/3C2/3S2/3M2
Extended ambient temperature range	operation: -20°C up to +55°C storage: -40°C up to +85°C transport: -40°C up to +85°C
RoHS-compliance	yes
Dimensions	311 x 483 x 355 mm (HxWxD) 19" Sub-Rack, 3U
Weight	App. 6.1kg without rectifier
Weight rectifier	app. 3.8kg



Front view of DCR PSR 327-8.1

Rectifiers

Switched rectifiers for parallel-redundant power supply systems of high availability in the energy sector, telecommunications and industry; hot plug-in; processorcontrolled, charging voltages and characteristic curves can be adjusted manually and remotely, can be used with all battery types.



Example configuration DCR PSR327-10.8 HV
4 x PSR327-220V

Control unit UPC3 with integrated fan

- Extensive battery management
- Freely programmable signalling concept
- „Hot-Plug-In“ design with backplane connection
- Integration of external alarm structures possible
- Remote controll. + monitoring via direct PC link, modem or SNMP
- CAN- Bus interface

Dimensions: 133x101x320 mm (HxWxD)
Weight: app. 1.8kgs



Control unit
UPC3

Rectifier module PSR327

Output voltage	Output current
110 (108)V	25A
220 (216)V	12.5A

Dimensions (HxWxD):
133x106.3x326.5mm
Weight: app. 3.8kgs

1/4 * 19" * 3U high to use in racks, all connectors on rear side, with or without PowerController UPC selectable, hot-swappable, (Compatible 19" rack: DCR PSR327-xx)



Rectifier module
PSR327-110V

Rectifier module PSS18

Output voltage	Output current
110 (108)V	13.3A
220 (216)V	6.7A

Dimensions (HxWxD):
262x142x285mm
Weight: app. 8.4kg

1/3-19" * 6U to use in racks as per DIN A 41 494, all connectors on front side (Compatible 19" rack: DCR PSS18-xx)



Rectifier module
PSS18-110V

Inverters



Left hand picture:
single 110 VDC module



Right hand picture: Assembly set 19" sub
rack 2U incl. backplane for 3pcs. inverters
INV2xx and 1pc. static switch STS207

Product description

An INV-series inverter includes the newest switching technology with digital control. Due to this fact a dramatic reduction of volume and weight was achieved. With a state-of-the-art control solution it provides an excellent functionality and several protection features.

The inverter is able to run in parallel operation mode to increase the reliability of the AC system without any additional options. Additional modules can be integrated in wired slots during normal system operation. For higher reliability the hard wired synchronization bus between paralleled inverters is working in a redundant mode.

Up to 4 inverters can be installed in a 19"-subrack with only 2U. The module is prepared to operate with the new static switches of the STS series to increase the system availability furthermore.

Key features

- 1/4 x 19", 2U
- Excellent overall efficiency and high regulation speed
- "Hot plug-in" design with backplane connection
- High power density
- CAN-Bus interface
- Ability for parallel operation
- Temperature-controlled fan cooling
- Redundant synchronization bus
- Excellent sinusoidal output
- Input over/under voltage shutdown, overload and short circuit-proof

Available versions:

Type	input	output	capacity
INV222	110VDC	230VAC	2.25kVA
INV222	220VDC	230VAC	2.25kVA

Charger

NEU / NEW

EFFEKTA® CHA-series



Description

12, 24 and 48V Charger

The EFFEKTA® chargers offer a rapidly and gently charging process with IUoU-characteristics. Thereby they are ideal for charging lead-gel, lead-acid and AGM batteries.

This 3-steps constant current charging in professional quality, batteries charge faster and more gently than comparable units on the market, whereby the service life of the batteries significantly increase.

With the IUoU-characteristics, charge occurs with constant current until the gassing voltage. After a certain gassing time the voltage reduces to trickle charge.

Hereby each battery can be charged up to its maximum capacity.



Features

- Reverse polarity- and short circuit protection
- Overload protection
- IUoU-charging characteristic
- High efficiency through switching power supply-technology
- Temperature-controlled fan
- 24 months' warranty

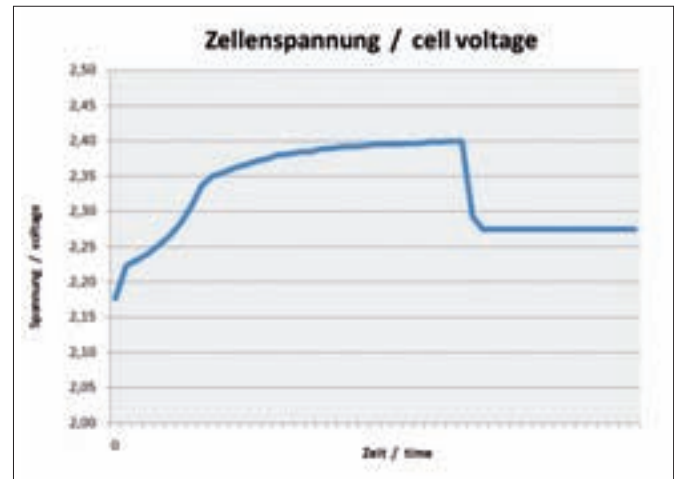
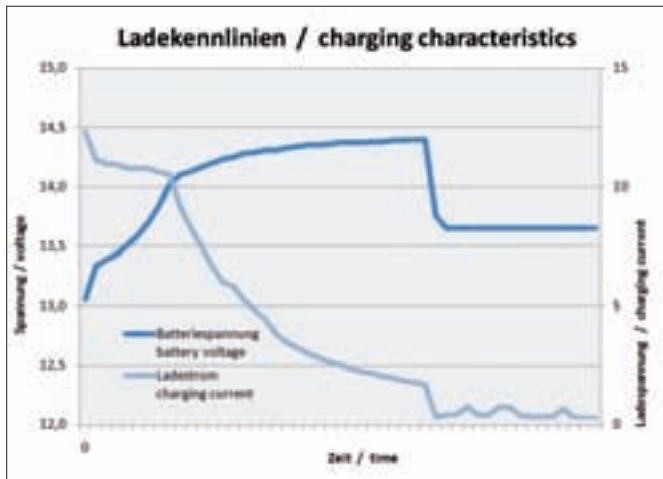

Specifications

12 V - Model	CHA 012-012	CHA 012-025
Input voltage	230VAC ± 10%	
Frequency	50Hz	
Output voltage	12VDC	
Charging end voltage	14.4VDC	
Charging maintenance voltage	13.6VDC	
Charging current max.	12A	25A
Operating temperature	0-50°C	
Weight	2.1kg	2.7kg
Dimensions (H x W x D in mm)	82 x 205 x 230	82 x 205 x 290

24 V - Model	CHA 024-008	CHA 024-014
Input voltage	230VAC ± 10%	
Frequency	50Hz	
Output voltage	24VDC	
Charging end voltage	28.8VDC	
Chrging maintenance voltage	27.2VDC	
Charging current max.	8A	14A
Operating temperature	0-50°C	
Weight	2.1kg	2.7kg
Dimensions (H x W x D in mm)	82 x 205 x 230	82 x 205 x 290

48 V - Model	CHA 048-008
Input voltage	230VAC ± 10%
Frequency	50Hz
Output voltage	48VDC
Charging end voltage	57.6VDC
Charging maintenance voltage	54.4VDC
Charging current max.	8A
Operating temperature	0-50°C
Weight	2.7kg
Dimensions (H x W x D in mm)	82 x 205 x 290



Right picture: rear view of EFFEKTA® charger model 24-14 (24V, 14A) with fan, solid cable and fuse













Chargers

Switch-mode chargers for lead-acid batteries, with IUoU-characteristic, timer for float charge, low ripple, leads with battery clips, waterproof (IP67) version available





MA 2040

MA 2045

 MA2040    	135x80x44mm (L x B x H) app. 350g		Nominal voltage	Output current
			12V	4A
			24V	2A
 MA9740    	(no pic.) 184x171x54mm(LxBxH) app. 1.7kg		Nominal voltage	Output current
			12V	10A
			24V	5.0A
			36V	3.3A
			48V	2.5A
 MA2045  	215x186x63.5mm (LxBxH) app. 2.2kg		Nominal voltage	Output current
			12V	20A
			24V	10A

Mascot AC/DC plug-in units switch mode:

AC/DC plug-in units with universal input voltage and high efficiency, short circuit-proof, output cables with exchangeable plugs, EN60601 on request.

 MA9725 75x32x40mm (LxBxH) app. 65g	Output voltage	Output current
	5V	1A
	6V	1A
	7.5V	0.7A
	9V	0.6A
	12V	0.6A
 MA9619 100x63x47mm (LxBxH) 250g	Output voltage	Output current
	7.5V	3.0A
	9V	2.8A
	13V	2.4A
	18V	1.7A
	24V	1.3A





MA9725

MA9619

Mascot AC/DC power supplies switch mode:

AC/DC power supplies, primary switched, short circuit-proof, 190-264VAC / 260-340VDC, 6.3mm push-on terminals, inc. earth, cable, hand lamp or cigarette lighter plug, output voltage adjustable on charging voltage.

 MA9120 122x77.5x42mm (LxBxH) app. 400g	Output voltage	Output current
	7.5V	3.0A
	9V	4.5A
	10V	3.5A
	12V	2.7A
	25V	2.0A
 MA8921 215x151x62mm (LxBxH) 1.55kg	Output voltage	Output current
	12V	20A
	24V	12A
	48V	6A



MA9120

MA8921

DC/DC converters

For use as a mains source in cars, boats and for other mobile applications.



MA8662



MA8862		
Switched mode DC/DC converter, output isolated for vehicle use		
135x119x46mm (LxWxH) app. 600g	Input voltage	18-32V
	Output voltage	13.2 / 24 / 48V
	Power contin.	81W
	Peak power	132W
Available types:		
Input range	Fixed output	Contin.current
10-16V	13.2V	3A
10-16V	24V	1.7A
10-16V	48V	0.7A
18-32V	13.2V	6A
18-32V	24V	3A
18-32V	36V	2.5A
18-32V	48V	1.5A
30-48V	13.2V	6A
30-48V	24V	3A
MA9970		
Switched mode DC/DC converter, output isolated for vehicle use		
MA9970 203x102x63mm (LxWxH) 0,9kg	Input voltage	20-30V
	Output voltage	13.8V
	Power contin.	276W
	Peak power	317W



MA8662		
Linear regulated CD/DC converter for vehicle use		
129x115x62 mm (LxWxH) app. 500g	Input voltage	20-32V
	Output voltage	13.5V / 6A
	Power contin.	80W
	Peak power	100W



MA8862



MA9970

Solar inverter ES-series

NEU / NEW

Grid-connected

ES3300 – 3000watt

ES4200 – 4000watt

ES5000 – 5000watt

The EFFEKTA® ES inverters with an output power of 3000 up to 5000Watt are ideally suitable for several solar modules. With its robust assembly in dustproof IP65 cabinet, the application range is nearly unlimited.



Features

- Transformer-less with high efficiency (96%)
- Wide range of working temperature:
-25°C bis +50°C
- Intelligent MPP-Tracking
- Suitable to operate either indoor or outdoor (IP65)
- Fan-less through convection cooling
- RS232-communication
- Wide communication equipment:
Slots for RS485 USB,
relays card or TCP/IP
- 5 years' warranty
(optionally expandable to 10 years)

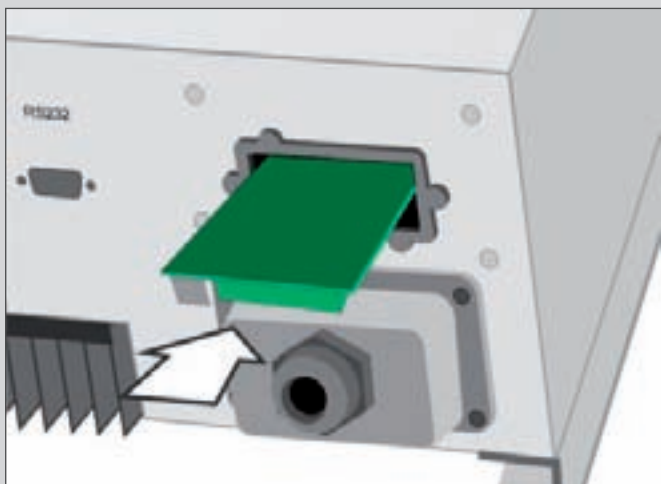

Slot for optional communication cards

Comfortable multifunction panel

1. LCD-Display
2. Warning-LED rounding failure
3. Warning-LED supply failure
4. LED-display supply OK
5. Access functions
6. Click back
7. Click forward
8. Confirm





Easy and secure mounting with carrier plate

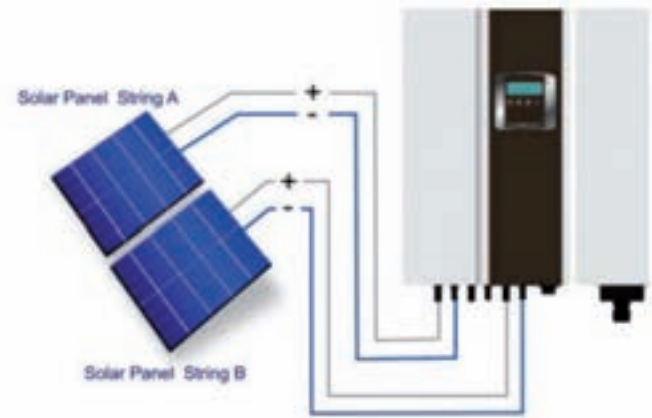

Sample configuration:
DC-connection clamp for one 2-String-PV-array

Specifications

Model		ES3300	ES4200	ES5000
Inverter technology	Implementation	sine-wave, current source, change-/high-frequency PWM		
	Isolation method	version without transformer*		
DC-input	Nominal voltage	360VDC		
	Max. input voltage	500VDC		
	Operating voltage	120VDC to 500VDC**		
	Max. current (each MPP-Tracker)	22A	14A	17.65A
	MPPT range	150VDC to 450VDC		
AC-output	MPPT tracker	1	2	
	Nominal power	3000	4000	4600
	Max. power	3300	4200	5000
	Nominal voltage	230 VAC adjustable on 200/208/220/230/240		
	Form of the output connection	1-phase, mains connection (L, N, PE)		
	Voltage range	184 to 264.5 VAC (basic 230 VAC)		
	Nominal current	13A	17.7A	21.7A
	Frequency	50/60Hz, autoselect		
	Power factor	>0.99 with nominal AC		
	Harmonic distortion	total harmonic distortion: under 5% single harmonic distortion: under 3%		
Efficiency	Max. efficiency	>96%		
	EURO efficiency	>94%		
	CEC efficiency	>94%		
Environment	Operating temperature	-25°C up to +50°C (-13°F up to +122°F)		
	Humidity	0 to 90% (without condensation)		
	Audible noise	<45dBA		
Mechanic	Dimensions (H x W x D in mm)	455 x 430 x 170	455 x 510 x 170	
	Weight (kg)	25	29	
	Enclosure	IP65, outdoor operating		
	Cooling	convection		
	AC connection	terminal		
	DC connection	multiple, pluggable		
Communication	Standard	RS232		
	Optional	USB, RS485, potential free contact, TCP/IP		
Frontpanel	LCD	input DC voltage/input DC current/input DC current capacity/ output AC voltage/output AC current/output frequency/output AC current capacity/ energy output/inside temperature/cooling body temperature/status signal/failure signal		
	LED	red:	grounding failure or DC-input insulation failure	
	Keyboard	yellow:	supply conditions are not comply with input values of photovoltaic inverter	
Safety	Mains supply	over-/under voltage, over-/under frequency, grounding failure, DC-input insulation failure, off-grid operation		
	Short circuit	AC input: input diode/electrical switching AC output: output relay/electrical switching		
	EPO	photovoltaic inverter switches off immediately		
	Over temperature	≤50°C (122°F) at full power/≥50°C (122°F) at reduced power		
Certification	Safety	Europe VDE0126-1-1, EN50178, IEC62103		
	EMI/EMC	EN61000-6-1, EN61000-6-2, EN61000-6-3, EN61000-6-4		

*no galvanic isolation – note installation introduction of the solar-panel manufacturer..

**nominal range should be from 150 VDC up to 500 VDC to achieve the nominal capacity.

Solar-Log™ Monitoring

Remote diagnostic system for
EFFEKTA® solar inverter ES

NEU / NEW



The microcomputer Solar-Log™ offers the owner or installer an easy installation coupled with a large range of functions for their photovoltaic system.



Solar-Log²⁰⁰ for
1 inverter

Solar-Log™ enables you to monitor and manage your photovoltaic system yourself. The main focus is on performance and yield control. Selectable display methods, data security and our free web based service are further plus-points that speak for Solar-Log™.

Solar-Log™ constantly monitors the performance of each and every inverter/string and evaluates the status messages. Specific alert message protocols allow fast response times and prevents loss of revenue.

Features and advantages

- Low cost – high benefit
- Easy installation and operation
- Solar-Log⁵⁰⁰ provides up to 10 inverters
- Solar-Log¹⁰⁰⁰ provides up to 100 inverters
- Endless, consistent data logging
- Centralized monitoring, remote configuration of multiple plants (via optional portal connection)
- Operating with touch-screen or web-browser in a network
- Service-orientated monitoring and analysis options
- User-friendly visualization of plant data
- Low losses of profit
- Earnings forecast
- Degradation of modules calculation
- Made in Germany
- 5 years warranty



Solar-Log⁵⁰⁰ for up to
10 inverters



Solar-Log¹⁰⁰⁰ for up to
100 inverters

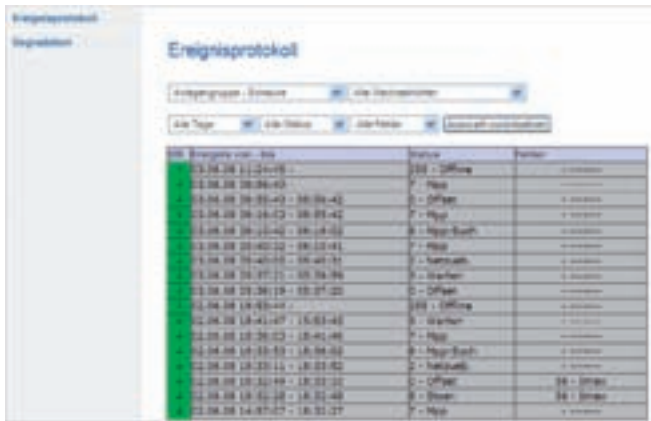

Event log retrievable via PC for detailed Diagnosis of Inverter (German language screenshot)



Graphical and tabulation view of daily, monthly and total values, reference value for annual yield, input voltage in daily view available. (German language screenshot).

Specifications

Model	Solar-Log 200	Solar-Log 500	Solar-Log 1000
Inverter communication / inverters			
Max. number inverters	1	10	100
Communication interfaces	1 x RS485 / RS422	1 x RS485 / RS422	1 x RS485, 1x RS485 / RS422
Inverter-mixed mode	–	–	•
Maximum unit size	15kWp	50kWp	1MWp
Maximum cable length	max. 1000m ¹⁾	max. 1000m ¹⁾	max. 1000m ¹⁾
Bluetooth ²⁾	optional, internal antenna	optional, internal antenna	optional, internal antenna
Power management ²⁾	–	–	•
System monitoring			
String monitoring (dependant on inverter-type)	•	•	•
Inverter breakdown	•	•	•
Performance monitoring per inverter	–	•	•
Status / error monitoring	•	•	•
Sensor connection (Irradiation / 2 x Temp. / Wind)	–	–	•
Connection of digital electric meters	–	•	•
Email and SMS alert	•	•	•
Local alert (floating contact)	–	–	•
Income forecast	•	•	•
Degradations calculation	•	•	•
Visualization			
Integrated web server	•	•	•
Graph. visualization - local PC	•	•	•
Graph. visualization - USB stick	–	–	•
Graph. visualization - Internet	•	•	•
LED status indicator	•	•	•
Display on device	–	2-line Dot matrix display	Full - graphic display
Operation on device	–	Keypad entry	via touch screen
Large display RS485 / S 0-Impuls	–	• / •	• / •
Interfaces			
Ethernet - Network	•	•	•
USB stick	–	–	•
Analog modem / GPRS (GSM) / DSL	–	–	•
Floating contact (relay)	–	–	•
Alarm contact (theft)	–	–	•
General data			
Power supply / Voltage		220 V / 12V	
Electricity consumption	3W	3W	3W
Ambient temperature		-10°C to +50°C	
Case		Plastic	
Dimensions (H x W x D) in cm		22.5 x 4 x 28.5	
Installation		Wall mounted	
Protection		IP 20 (only for indoor use)	
Connection to Solar-Log™ Portal	•	•	•
Multiple languages (DE, EN, ES, FR, IT, NL)	•	•	•
Memory, Micro-SD, 2 GB, endless data-recording	•	•	•
Warranty		5 years	

¹⁾Depending on the inverter and the cable length (Figures may vary depending on the type of device)

²⁾Other important information on Bluetooth and compatibility can be found on www.solar-log.com

Inverter WRI

EFFEKTA® Inverter WRI-Series

NEU / NEW



Description

The new EFFEKTA® WRI-series inverters are suitable in the low and middle performance range as AC power supplies for mobile applications.

Features

- Output voltage 230V_{AC}
- Input voltage 12 or 24V_{DC}
- Available with 150, 300, 500, 700, 1000, 2000, 3000, 4000 or 5000Watt
- Compact design
- Minimal weight
- Battery low alarm
- Overload-/voltage reversal-/short circuit-safe
- Overheat control



Specifications

Model	WRI-150	WRI-300	WRI-500
Max. continuous power (W)	150	300	500
Surge capability (W)	300	600	1000
Output voltage	RMS 230V _{AC} ±10%		
Output frequency	50Hz ±4Hz		
Optimum efficiency (App.)	85%		
No load current draw (A)	≤0.5	≤0.5	≤0,5
Input voltage	12Volts (24Volt)		
Low battery alarm	10.5-11.1Volts (20.0-21.0Volts)		
Low battery shutdown	9.8-10.4Volt (19.1-19.9Volts)		
output wave form	Regulated modified sine-wave		
No. of AC connections	1		
Temperature	0°C to +40°C		
Replaceable fuse (Amps)	20A	30A	2 x 30A
Dimensions (H x W x D in mm)	155 x 122 x 51	175 x 122 x 51	195 x 170 x 61
Weight	0.75kg	1.00kg	1.55kg

Model	WRI-700	WRI-1000	WRI-2000
Max. continuous power (W)	700	1000	2000
Surge capability (W)	1600	2000	4000
Output voltage	RMS 230V _{AC} ±10%		
Output frequency	50Hz ±4Hz		
Optimum efficiency (App.)	85%		
No load current draw (A)	≤1.0	≤1.0	≤1.5
Input voltage	12Volts (24Volts)		
Low battery alarm	10.5-11.1Volts (20.0-21.0Volts)		
Low battery shutdown	9.8-10.4Volt (19.1-19.9Volts)		
Output wave form	Regulated modified sine-wave		
No. of AC connections	1	2	
Temperature	0°C to +40°C		
Replaceable fuse intern (Amps)	≥70	5 x 25A	6 x 30A
Dimensions (H x W x D in mm)	221 x 170 x 61	292 x 170 x 61	340 x 210 x 80
Weight	1.80kg	2.30kg	3.70kg

Model	WRI-3000	WRI-4000	WRI-5000
Max. continuous power (W)	2700	3600	4500
Surge capability (W)	3000	4000	5000
Output voltage	RMS 120/230V _{AC} ±10%		
Output frequency	50Hz ±4Hz		
Optimum efficiency (App.)	90%		
No load current draw (A) switch „on“	≤2.0A _{DC}	≤2.0A _{DC}	≤1.2A _{DC}
No load current draw (A) switch „off“	≤0.2mA _{DC}	≤0.2mA _{DC}	≤0.2mA _{DC}
Input voltage	12Volts (24Volts)		
Low battery alarm	10.8Volts (21.5Volts)		
Low battery shutdown	10Volts (20Volts)		
Output wave form	Regulated modified sine-wave		
No. of AC connections	2	2	2
Temperature	0°C to + 40°C		
Replaceable fuse intern (Amps)	≥250	≥350	≥400
Dimensions (H x W x D in mm)	470 x 208 x 148	470 x 208 x 148	630 x 208 x 148
Weight	7.5kg	10.3kg	11.5kg

Inverters WRS

EFFEKTA® WRS-series

WRS-012-3000



Description

The EFFEKTA® WRS-series inverters are suitable in the low and middle performance range as AC power supplies for industrial and mobile applications.



Front view WRS-024-1500

Features

- Output voltage 230V_{AC}
- Input voltage 12, 24 or 48V_{DC}
- Battery low alarm
- Overload-/ voltage reversal-/short circuit-safe
- Screwable terminals on the rear side



Rear view WRS-024-1500



WRS-012-0700



WRS-024-0350

Specifications

Model	WRS-012-0200	WRS-024-0200	WRS-048-0200
Power	200W		
Output voltage	200/220/230/240V _{RMS} ±3%, 50/60Hz switchable		
Input voltage	12V _{DC}	24V _{DC}	48V _{DC}
Low.Bat.-Shutdown	10.0V _{DC}	20.0V _{DC}	42.0V _{DC}
Dimensions H x W x D	71 x 119 x 230mm		
Weight	1.2kg		

Model	WRS-012-1500	WRS-024-1500	WRS-048-1500
Power	1500W		
Output voltage	200/220/230/240V _{RMS} ±3%, 50/60Hz switchable		
Input voltage	12V _{DC}	24V _{DC}	48V _{DC}
Low.Bat.-Shutdown	10.0V _{DC}	20.0V _{DC}	42.0V _{DC}
Dimensions H x W x D	102 x 278 x 413mm		
Weight	7.2kg		

Model	WRS-012-0350	WRS-024-0350	WRS-048-0350
Power	350W		
Output voltage	200/220/230/240V _{RMS} ±3%, 50/60Hz switchable		
Input voltage	12V _{DC}	24V _{DC}	48V _{DC}
Low.Bat.-Shutdown	10.0V _{DC}	20.0V _{DC}	42.0V _{DC}
Dimensions H x W x D	71 x 119 x 230mm		
Weight	1.6kg		

Model	WRS-012-2000	WRS-024-2000	WRS-048-2000
Power	2000W		
Output voltage	200/220/230/240V _{RMS} ±3%, 50/60Hz switchable		
Input voltage	12V _{DC}	24V _{DC}	48V _{DC}
Low.Bat.-Shutdown	10.0V _{DC}	20.0V _{DC}	42.0V _{DC}
Dimensions H x W x D	102 x 278 x 413mm		
Weight	7.2kg		

Model	WRS-012-0700	WRS-024-0700	WRS-048-0700
Power	700W		
Output voltage	200/220/230/240V _{RMS} ±3%, 50/60Hz switchable		
Input voltage	12V _{DC}	24V _{DC}	48V _{DC}
Low.Bat.-Shutdown	10.0V _{DC}	20.0V _{DC}	42.0V _{DC}
Dimensions H x W x D	81 x 179 x 298mm		
Weight	2.8kg		

Model	WRS-012-3000	WRS-024-3000	WRS-048-3000
Power	3000W		
Output voltage	200/220/230/240V _{RMS} ±3%, 50/60Hz switchable		
Input voltage	12V _{DC}	24V _{DC}	48V _{DC}
Low.Bat.-Shutdown	10.0V _{DC}	20.0V _{DC}	42.0V _{DC}
Dimensions H x W x D	102 x 283 x 455mm		
Weight	10.6kg		

Model	WRS-012-1000	WRS-024-1000	WRS-048-1000
Power	1000W		
Output voltage	200/220/230/240V _{RMS} ±3%, 50/60Hz switchable		
Input voltage	12V _{DC}	24V _{DC}	48V _{DC}
Low.Bat.-Shutdown	10.0V _{DC}	20.0V _{DC}	42.0V _{DC}
Dimensions H x W x D	81 x 179 x 334mm		
Weight	3.8kg		

Special appliances

“Powermanager“

Processor-regulated uninterruptible power supply system with 230V/50Hz/200VA AC output, five separate 24V/20A DC-outputs, battery monitoring, protection monitoring, watch-dog, in accordance with VDE0828/EN60849.



Production-redundant

Telecom power supply 48V/1800A

48V/2.7kW/55A charging rectifiers makes up a parallel-redundant UPS system with two maintenance-free 48V/1000Ah batteries, 1800A inverter with central installation control, low-discharging protection and SNMP-interface.

Reference projects:

Waste incinerator in Bremen (ANO II)

GEW Köln tetra radio network

M³Net München

broadnet mediascape AG

VOITH Hydro Power





Product	MD-1
Application	Constructed for industrial systems
Features	Online double-conversion with integrated auto bypass Mounting height 4U, to achieve a shortened modular depth of 300mm. All power lines, outputs and sockets for control signal (floating contacts) on hardwired Phoenix terminals. Optimised for 19" switch cabinet
Basic unit	MH RM 2000

EFFEKTA® UPSs are not only suited for use in computers, but also for all sensitive, power-dependent units. We have a solution for every kind of application. We are also experienced in custom designs and small production runs. All models are available in standard enclosures or can be supplied for switchboards or DIN rails.



Product	GSV („Gesicherte Stromversorgung“ [german])
Application	The GSV is intended to provide the needed power to electric drive units for doors during powerfailures in emergency situations.
Features	The GSV provides up to 72 h standby mode and after that about 5 min with 500 W load. The system can be activated by an external dry contact. During a powerfailure after a delay (10 seconds default) a signal switch (500 ms impulse) will be sent to activate the electric drive unit. Back in normal mode the mains will be switched directly to the output. In normal mode the GSV-system is charging the internal batteries and in emergency mode it monitors the battery voltage. In- and output single phase hardwired Capacity 1000VA/670W (maximum 4,3 A) Cabinet prepared for wall assembly Electronics: IP65 Batteries: IP21 Dimensions (compl. HxWxD) 500x300x120 mm
Basic unit	MT 1000

Service

Overview of maintenance and service contracts

1) Performance-based service

- Date: as customer requires
- Cleaning the installation
- Check-up of the mechanical condition and all installation parts
- Voltage check of AC current inter-circle
- Control and possible alignment of oscillator circles
- Examination and adjustment of all electric control circuits of inverter and rectifier
- Control measurement of thyristors, diodes, transformers, filter-elements etc, to guarantee a perfect operation of installation
- Capacity test of the batteries as customer requires
- Exchange of defective batteries after prior approval of cost estimate
- Invoice: at the valid EFFEKTA® cost rate

2) Partial-maintenance contract including spare parts excluding batteries

- Date: 1x annually
- Cleaning the installation
- Check-up of the mechanical condition and all installation parts
- Voltage check of AC current inter-circle
- Control and possible alignment of oscillator circles
- Examination and adjustment of all electric control circuits of inverter and rectifier
- Control measurement of thyristors, diodes, transformers, filter elements etc, to guarantee a perfect operation of installation
- Capacity test of the batteries as customer requires
- Exchange of defective batteries after prior approval of cost estimate
- Fault hotline
(response time: 24 hours Mon-Fri 8am- 5pm)
- Spare parts covered by maintenance fee
- 15% discount on batteries
- Minimum contract period: 4 years
- Invoice: via maintenance fee

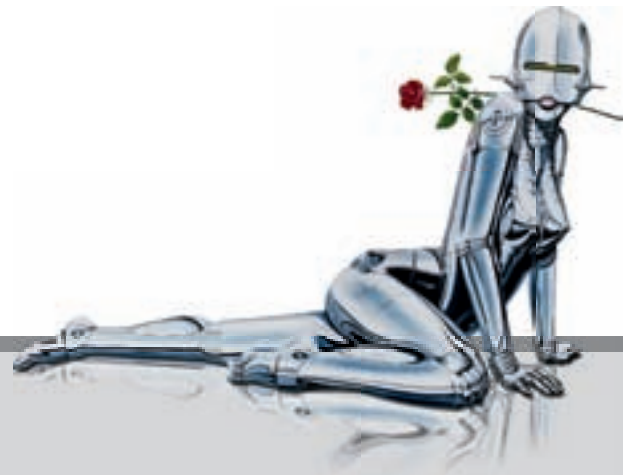

3) Full maintenance contract including spare parts and batteries

- Date: 1x annually
- Cleaning the installation
- Check-up of the mechanical condition and all installation parts
- Voltage check of AC current inter-circle
- Control and possible adjustment of oscillator-circles
- Examination and attitude of all electric control circuits of inverter and rectifier
- Control measurement of thyristors, diodes, transformers, filter elements etc, to guarantee a perfect operation of installation
- Capacity test of the batteries as customer requires
- Exchange of defective batteries
- Fault hotline
(response time: 24 hours Mon-Fri 8am- 5pm)
- Spare parts and batteries via maintenance fee
- Minimum contract period: 4 years
- Invoice: via maintenance fee

Reference

Industry:

- Alstom Turbinen..... Nuremberg
- BASF AG..... Ludwigshafen
- BASF AG..... Willstätt
- Bayer Leverkusen..... Leverkusen
- Bayer Vital..... Fernwald
- BMW AG..... Munich
- Bombardier..... Braunschweig
- Burda Rechenzentrum..... Munich
- Daimler Chrysler..... Stuttgart
- Daimler Chrysler..... Rastatt
- Deutsche Messe AG..... Hannover
- Deutscher Wetterdienst..... Offenbach
- Festo..... Esslingen
- Georg Fischer..... Singen
- Gerolsteiner Brunnen GmbH..... Gerolstein
- Hoechst AG..... Frankfurt
- Hoechst AG..... Wiesbaden
- Höft und Wessel AG..... Hanover
- Kaufhof..... Cologne
- Klöckner Stahl GmbH..... Bremen
- Mattson..... Plietzhausen
- Mediamarkt..... Velbert
- Merck KG aA..... Grafing
- Mitropa..... Berlin
- Obi..... Martinsried
- Ravensburger Spiele GmbH..... Ravensburg
- Scheidt & Bachmann..... Mönchengladbach
- TNT..... Troisdorf
- VW..... Wolfsburg
- Walter AG..... Tübingen

Banks:

- BHF Bank..... Frankfurt
- Kreissparkasse..... Friedrichshafen
- Sparkasse..... Dillenburg
- Volksbank..... Altshausen
- Volksbank..... Biberach
- Volksbank..... Dreieich
- Volksbank..... Friedrichshafen
- Volksbank..... Gardeling
- Volksbank..... Saulgau
- Volksbank..... Tettngang
- Volksbank..... Weingarten
- Volksbank..... Donaueschingen

Sports facilities:

- Bayarena..... Leverkusen
- Nürburgring..... Nürburg
- Stadion der Freundschaft..... Cottbus
- SAP Arena..... Mannheim
- Mercedes Benz Arena..... Stuttgart

Universities:

- Universität..... Heidelberg
- Universität..... Wuppertal
- Universität..... Ulm
- Universität..... Konstanz
- Universität..... Tübingen
- Universität..... Regensburg
- Universität der Bundeswehr..... Hamburg
- Universität Gesamthochschule..... Soest
- Fachhochschule..... Frankfurt
- Fachhochschule..... Stuttgart
- Fachhochschule..... Mannheim
- Fachhochschule..... Dortmund
- Fachhochschule..... Darmstadt
- Fachhochschule..... Giessen

Hospitals:

- Albklinik..... Münsingen
- Bundeswehrkrankenhaus..... Amberg
- Kliniken Landkreis..... Sigmaringen
- Krankenhaus St. Martin..... Duderstadt
- Krankenhaus Bad Cannstatt..... Stuttgart
- Krankenhaus Stadt Chemnitz..... Chemnitz
- Krankenhaus Sachsenhausen..... Frankfurt
- Städtisches Krankenhaus..... Friedrichshafen
- Städtisches Krankenhaus..... Dresden

Authorities:

- Berliner Verkehrsbetriebe (BVG) Berlin
- Abfallbehandlung Nord Bremen
- AOK Brandenburg Potsdam
- Embassy of the United Arab Emirates Berlin
- Finanzamt Schweinfurt
- FTZ Eschborn
- Kläranlage Griesheim
- Kläranlage Langenhagen
- Kreisverwaltung Mansfeld
- Landesvermessung Dresden
- Landesvermessung Potsdam
- Landeswohlfahrtsverband Kassel
- Landratsamt Friedrichshafen
- Landratsamt Mosbach
- Max-Planck-Institut Golm
- Max-Planck-Institut Stuttgart
- Messe AG Hanover
- Polizeipräsidium Wiesbaden
- Sancura BKK Wetzlar
- Stadtverwaltung Frankfurt
- Stadtverwaltung Halle
- Stadtverwaltung Konstanz
- Stadtverwaltung Schwalbach

Telecommunications:

- Broadnet Mediascape Hamburg
- DeTe Mobil AG Bonn
- Deutsche Telekom AG Weilheim
- T-Mobile Leipzig
- M-net GmbH Munich
- SCALTEL AG Waltenhofen
- TeleData GmbH Friedrichshafen

EFFEKTA Austria:

- AGIP Austria GmbH Wien
- Agrana Fruit Austria GmbH Allhartsberg
- Allgemein österr. Bezirkskrankenhaus St. Johann in Tirol
- AUVA Wien
- Bezirksgericht Kirchdorf Kirchdorf
- Bob- und Rodlbahn Igls
- BTV AG Innsbruck
- Bundesministerium für Justiz Wien
- Daily Service Tiefkühllogistik GmbH Asten
- Dornbirner Messe GmbH Dornbirn
- Ebewe Pharma GesmH Unterach am Attersee
- Energie Control GmbH Wien
- Erber AG Herzogenburg
- Fiber Cable Technologie Gmünd
- Gartner KG Lambach
- Haidlmaier GmbH Nussbach
- Hit FM Privatrado Krems / St. Pölten
- Hypo Bank Wien
- IGM Robotersysteme Wien
- Interwetten AG Wien
- Isovolta AG Werndorf / Lebring
- Kirchdorfer Zementwerk Hofmann GmbH Kirchdorf
- Kraft Foods Österreich GmbH Wien
- Landessicherheitszentrale Burgenland Eisenstadt
- Landhaus 2 Innsbruck
- Manpower GmbH Wien
- Net4You Internet GmbH Villach

International:

- Praktiker Hungary
- Messer Hungarogaz Hungary
- Osram China
- Philips Israel
- Euroforum Trade Center Luxembourg
- Patentamt Vienna/Austria
- Deutsche Babcock United Arab. Emirates
- Deutsche Botschaft Nairobi
- Olympiahalle Innsbruck/Austria
- Migros Markt Zürich/Switzerland
- Zollamt Zürich/Switzerland

- Several in Riga/Latvia, Hungary, Switzerland, Spain, UK, Sweden, USA, Saudi Arabia, China, Taiwan

Terms & Conditions

Terms and conditions for sales and delivery of EFFEKTA Regeltechnik GmbH, Rottweil

Preamble

The following terms and conditions for sales and delivery form the basis of the delivery and service contracts of the contractor (user) and supplement the applicable law. They are only applicable to businesses where the contract is made in the course of their business, legal entities of the public law or special authorities under public law.

I. Application

- Orders only become binding with regard to the type and scope of deliveries after the supplier confirms the order. Any changes and additions must be in writing.
- Where ongoing business relationships subsist, these terms and conditions also apply to future transactions even where they are not expressly communicated to the orderer. The terms and conditions are deemed to be accepted at the latest when the order is placed or the delivery or service is accepted. If alternative provisions of the orderer or supplier are to apply instead of these terms and conditions, these must be expressly agreed by the partners.
- Contrary or divergent sales terms of the orderer shall only be binding on the supplier if they have been expressly acknowledged by him in writing.

II. Prices

- A binding price shall only be deemed to have been set after the supplier confirms the order in writing. This is subject to the proviso that the order details on which the order confirmation is based remain unchanged. The supplier's prices are in EUR exclusive of any VAT applicable at the time of the delivery, unless other information is specified.
- If, in the course of a delivery period of more than four months, a change to the price basis occurs (increase in the price of raw materials, change of salary and wage rates), the supplier reserves the right to adjust the price accordingly.
- Packaging, postage and other shipping costs are not included and will be invoiced additionally.
- The orderer shall bear the costs of any changes to the product he requests after the order has been confirmed.
- Partial deliveries may be invoiced separately.

III. Delivery quantity, delivery period

- Production-related over- or underdeliveries of up to 10% of the order quantity are permitted.
- The supplier is permitted to make partial deliveries.
- The delivery periods commence with the date of order confirmation by EFFEKTA - Regeltechnik GmbH. The delivery periods specified by the supplier refer to the shipping date of the goods. They shall be deemed to have been observed if at this time the goods are dispatched from the factory or the orderer is informed that they are ready to be shipped.
- The agreed delivery time is only applicable after all technical and commercial details have been settled.
- Accordingly, all delivery times are provisional. Delivery times are only binding where they have been confirmed to the orderer as such in writing.
- If action on the part of the orderer is necessary for the manufacture of an item or the execution of a delivery, the delivery period shall not commence until the orderer has fully completed this action.
- In the event of a delay in delivery, the orderer may withdraw from the contract should a reasonable grace period expire without results. In the event of impossibility of performance on the part of the supplier, this right is available without the supplementary period. Delay in delivery is deemed to amount to impossibility if delivery does not occur for more than one month. Claims for damages (incl. any consequential loss) are excluded, without prejudice to clause 7; the same applies to reimbursement of expenses.
- The exclusion of liability regulated by clause 6 shall not apply where an exclusion or limitation of liability for damages for death, personal injury or damage to health resulting from a wilful or negligent breach of duty by the user or vicarious agents of the supplier has been agreed; further, it shall not apply where an exclusion or limitation of liability for other loss resulting from a wilful or grossly negligent breach of duty by the supplier or a wilful or grossly negligent breach of duty by a legal representative or a vicarious agent of the supplier has been agreed.
- Liability shall not be excluded where the supplier culpably breaches a fundamental contractual duty or a "cardinal duty", but instead limited to the foreseeable damages typical for the type of contract.
- The above applies correspondingly in the event of reimbursement of expenses.
- The limitations of liability stipulated in clauses 6 and 7 do not apply insofar as a commercial firm was agreed; the same also applies where the orderer can assert that he no longer has an interest in fulfilling the contract due to a delay for which the supplier is at fault.
- In the event of forces majeure experienced by the supplier or his subsuppliers, the delivery time shall be prolonged by a corresponding amount. This shall also apply in the event of intervention by official bodies, difficulties with the supply of energy and raw materials, strikes, lockouts and unforeseen obstacles to delivery, insofar as these are not the fault of the supplier. The supplier shall inform the orderer of any such event without delay.

IV. Transfer of risk, packaging and shipping

- Where the orderer collects the goods from the supplier's premises, risk passes with transfer of the goods to the orderer. Where the goods are shipped, risk passes on transfer of the goods to the carrier. Where the goods are delivered, risk passes when the goods leave the supplier's premises.
- In the event of delays to dispatch that are the fault of the orderer, risk passes on communication of readiness for shipping.
- Insofar as nothing else has been agreed, the supplier shall select the packaging and shipping type to the best of his judgment. Where requested in writing by the orderer, the goods may be insured against breakage, transport and fire damage at the orderer's expense.

V. Retention of title

- The supplier shall retain title to the deliveries until all current and future amounts due from the business relationship have been settled, even where the purchase price of specifically designated amounts due has been paid. In the case of rolling invoices, the retained title of the deliveries (goods subject to retention of title) counts as a security for the payment of amounts due on the supplier's account.
- In the event of conduct constituting a breach of contract on the part of the orderer, in particular late payment, the supplier is entitled to reclaim the goods. The orderer hereby agrees to the goods being reclaimed under these circumstances. Reclaiming the goods only represents a withdrawal from the contract where the supplier expressly declares this to be such. Any costs incurred by the supplier in reclaiming the goods (in particular transport costs) shall be borne by the orderer. Further, the supplier is authorised to prevent the orderer from selling on or processing the goods subject to retention of title and to revoke any direct debit authorisation that may have been issued. Once the purchase price and all costs have been paid, the orderer can require any goods reclaimed without an express declaration of withdrawal to be despatched.
- The orderer undertakes to handle the goods with care.
- The orderer may neither mortgage, pledge as security nor assign the goods delivered and corresponding amounts due. In the case of seizure or other third-party intervention, the orderer shall immediately inform the supplier in writing in order for him to file a claim in accordance with section 771 of the Civil Procedure Code. Any remaining costs outstanding to the supplier despite successful litigation as per section 771 of the Civil Procedure Code shall be borne by the orderer.
- The orderer is permitted to sell on, process or mix the goods in the normal course of business. In doing so he hereby assigns to the supplier all amounts due from selling on, processing, mixing or other legal grounds (in particular from insurance or non-permitted actions) to the extent of the final invoice amount agreed with the supplier (incl. VAT).
- The orderer remains authorised to collect these amounts due even after assignment, without prejudice to the authorisation of the supplier to collect the amounts due himself. However, the supplier undertakes not to collect the amounts due for such time as the orderer fulfils his payment obligations from the revenue received, is not in default of payment and no application to instigate insolvency proceedings has been made and no suspension of payment is in force.
- If this is the case, the orderer is required to notify the supplier on request of the assigned amounts due and debtors, to provide all information required for collection, to deliver up the associated documents and to notify the debtor (third party) of the assignment. The direct debit authorisation may be revoked by the supplier in the event of breaches of contract (in particular payment default) by the orderer.
- The retention of title also extends to the products arising as a result of processing, mixing or combination of the delivered goods to the extent of their full value, whereby these processes shall be deemed by the supplier to constitute manufacture. In the event of processing, mixing or combination of the goods with goods to which a third party retains title, the supplier obtains co-ownership in proportion to the objective values of these goods.
- For the purpose of securing the amounts due against the supplier, the orderer also assigns to the supplier the amounts due which arise in favour of a third party through the combination of the delivered goods with land.
- The securities owing to the supplier are not included where the value of his securities exceeds the value of the secured claims by more than 30%.
- The enforceability of the retention of title in the event of default on payment or exposure to loss and seizure of the delivered goods by the supplier represents withdrawal from the contract.

VI. Terms of payment

- All payments must be made in Euros exclusively to the supplier.
- Insofar as nothing else has been agreed, the purchase price must be paid via cash on delivery or advance cheque. In the latter case delivery shall proceed once the cheque has cleared. In exceptional cases payment terms of 14 days strictly net may apply.
- If the orderer defaults on payment, the supplier is permitted to demand default interest at eight percentage points above the base interest rate. The supplier may at any time produce evidence of higher interest damages and charge for these.
- Failure to observe the terms of payment, default or circumstances that pose a risk of reducing the orderer's creditworthiness will result in all of the supplier's claims becoming due for payment immediately. Further, the supplier is permitted after a reasonable grace period to withdraw from the contract or demand damages instead of performance.
- The orderer may only exercise offsetting rights if his counterclaims have been legally established, are indisputable or have been acknowledged by the supplier.
- The orderer is permitted to exercise a right of retention insofar as his counterclaim is based on the same contractual relationship.
- The supplier is under no obligation whatever to accept cheques and bills of exchange. Credit of this type is in all cases subject to redeemability (on account of payment, not on account of performance) and is deemed to be redeemed on the day that redemption value is available to the supplier. In the case of bills of exchange, any discount on presentation, stamp duty, bank charges and any direct debit charges shall be passed on by the supplier.
- The right to pursue any further contractual or statutory claims in the event of default is reserved.

VII. Responsibility for defects

If the orderer fulfils the duty of inspection, notification and rejection required of him in accordance with section 377 of the Commercial Code, the supplier is liable for defects of the delivery to the following extent:

- In the event of a not inconsiderable defect of the purchased goods, the supplier may choose either to correct the defect or supply a defect-free product (supplementary performance). In the event of failure of the supplementary performance, the supplier is authorised to undertake a further act of supplementary performance. Further, in the event of repeated supplementary performance, the supplier decides between re-supply or correction of the defect. Should one or both of these methods of supplementary performance be impossible or not proportionate, the supplier is permitted to refuse them. The supplier may also refuse supplementary performance for such time as the orderer does not fulfil his payment obligations towards him proportionate to the defect-free part of the performance.
- If supplementary performance as per clause 1 is impossible or fails, the orderer has the right either to reduce the purchase price accordingly or withdraw from the contract in accordance with the statutory provisions. These rights are open to the purchaser particularly where the supplier culpably delays or refuses the supplementary performance or if it fails for a second time. Insofar as the following (clause 4) does not provide otherwise, further claims of the orderer, regardless of their legal ground (in particular claims arising from the breach of contractual conditions and warranties, reimbursement of expenses with the exception of that provided for in section 439 subsection 2 of the German Civil Code, unlawful acts and other tortious liability) are excluded. This applies in particular to claims for damages beyond the thing purchased and for claims for the reimbursement of lost profits. This also covers claims that do not result from the defectiveness of the thing purchased.
- The above provisions also apply to the delivery of a different item or a lesser quantity.
- The exclusion of liability under clause 2 does not apply where an exclusion or limitation of liability for damages for death, personal injury or damage to health caused as a result of a wilful or negligent breach of duty by the user or wilful or negligent breach of duty by a legal representative or vicarious agent of the user has been agreed. It also does not apply where an exclusion or limitation of liability for other damages caused as a result of a wilful or negligent breach of duty by the user or wilful or negligent breach of duty by a legal representative or vicarious agent of the user has been agreed. Liability shall not be excluded where the supplier breaches a fundamental contractual duty or a "cardinal duty", but instead limited to the foreseeable damages typical for the type of contract. It is further excluded under clause 2. The exclusion of liability shall not apply if liability for personal injury or material damage to privately used items in the event of defects to the thing supplied applies under the Product Liability Act. Further, this also applies in cases covered by a guarantee by the supplier or where assurances were made as to specific properties of the goods purchased. Here a defect in this regard triggers the supplier's liability. The above applies correspondingly in the event of reimbursement of expenses.
- Claims for supplementary performance, damages and replacement goods/services are subject to a time limit of one year after delivery of the goods.
- This does not apply to goods which have been deployed in a building in accordance with their standard application and have caused this to become defective. The time limit here is five years.
- Claims for abatement and the exercise of the right to withdraw from the contract are excluded where the time limit for a claim for supplementary performance has been exceeded.
- In the case of clause 3 the purchaser may refuse to pay the purchase price to the extent that he would be entitled in the event of withdrawal or abatement. In the case of an exclusion of withdrawal and subsequent refusal to pay, the supplier is permitted to withdraw from the contract.
- Claims resulting from right of recourse to the producer are not affected by this section.
- No liability is accepted for damage resulting from unsuitable or improper use, defective installation by the orderer or a third party, defective or negligent handling or natural wear. Further, the supplier bears no liability for any damages caused by unsuitable equipment, defective building work, replacement materials, chemical and electrochemical or electrical influences (insofar as these are not the fault of the supplier) and improper alterations or maintenance work made without prior approval of the manufacturer on the part of the orderer or third parties. The same applies to unauthorised re-working or improper handling.
- Transport damages must be reported immediately to the delivering transport company. The carrier's instructions on subsequent procedure must be followed in all cases. Never should goods damaged in transit be sent to us either through us or the transport company without such instructions.

VIII. Breaches of duty

- The supplier's liability for breach of duty is limited to grossly negligent or wilful breaches of duty.
- Any liability for the infringement of intellectual property rights of third parties is excluded, in particular when performing production tasks in accordance with the orderer's specifications. The supplier is not subject to a duty of scrutiny in regard to the intellectual property rights of third parties.

IX. Software

Insofar as programs are part of the scope of delivery, the orderer obtains individual unlimited usage rights, that is he may not copy them or use them for any other purpose. Multiple usage rights shall be subject to written agreement. In the event of an infringement of these usage rights, the purchaser shall be liable for the full extent of any resultant loss.

X. Place of performance, jurisdiction and applicable law

- The place of performance is Rottweil.
- The court of jurisdiction is Rottweil, insofar as the orderer is trading in the course of a business. The supplier is permitted to bring an action against the orderer in other permissible jurisdictions.
- The law of the Federal Republic of Germany applies with regard to all claims and rights resulting from this contract. The application of UN sale of goods law (CISG) is expressly excluded.

XI. Closing provisions

- Any changes to the contract or supplementary agreements are only effective if they have been approved in writing by the supplier.
- Rights of the orderer arising from the legal transaction with the supplier are not transferable.
- Should any individual provisions of these terms and conditions become partially or wholly ineffective or invalid, this shall not affect the validity of the remaining provisions. The parties to the contract undertake to agree to a ruling by means of which the purpose intended by the ineffective or invalid provision is largely achieved.

(As of: November 2006)

